

MUGEN COATING PREMIUM  
2-Flute Long Neck Ball End Mill  
for Hardened Steel

**MRBH230**



Long neck ball end mill supports machining from prehardened steels to hardened steels (~ 65HRC)  
Abundant size variations with total 334 sizes

## MUGEN COATING PREMIUM

### 2-Flute Long Neck Ball End Mill for Hardened Steel

# MRBH230

R0.05 ~ R3 Total 334 sizes



## Features

Feature <b>1</b>	<b>Coating</b>	<b>Performance of MUGEN COATING PREMIUM</b>
---------------------	----------------	---

MUGEN COATING PREMIUM is a further improvement of the conventional MUGEN COATING that dramatically extends tool life during direct milling on hardened steels

It is effective in machining work materials with hardness from 40 to 65 HRC



**Feature 2** Cutting edge shape **Spiral shape • Back taper shape**

2-1

Adopt stronger spiral shape than conventional  
Resist chattering by improved cutting ability  
of center R where has high cutting load

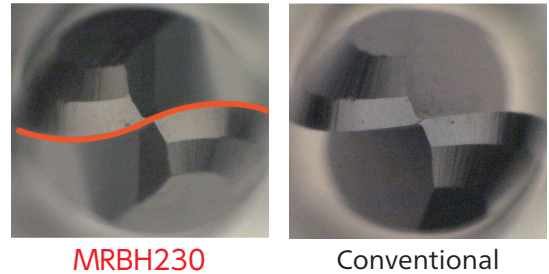





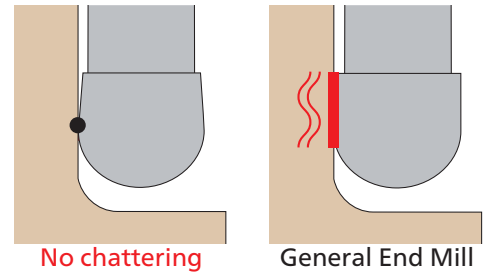



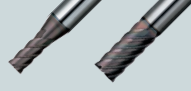

2-2

Adopt back taper shape for the peripheral  
edge to suppress chattering that occurs due to  
increasing cutting load  
The cutting load is reduced by point cutting  
that realizes stable machining surface

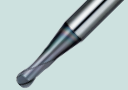

**Feature 3** Abundant line up **MUGEN COATING PREMIUM Series**

	Square End Mill	Ball End Mill	Corner Radius End Mill
Full Cutting Length Type	<b>MXH225, MXH230, MXH235 MXH240, MXH245</b>  All round type with L/D 1~5 times	<b>MSBH230</b>  Multi-purpose from roughing to finishing	<b>MHDH445R MHDH645R</b>  Corner radius end mill suitable for hardened steels (~ 65HRC)
	<b>MXH225P, MXH230P, MXH235P</b>  Sharp edge type with L/D 1~3 times	<b>MSBH345</b>  3-flute strong helix angle ball end mill	
	<b>MHDH445 MHDH645</b>  Suitable for finishing on hardened steels (~ 65HRC)		
Long Neck Type	<b>MHRH230 MHRH430</b>  Suitable for deep milling on prehardened steels and hardened steels (~ 65HRC)	<b>MRBH230</b>  Ball end mill suitable for hardened steels (~ 65HRC)	<b>MHRH230R MHRH430R</b>  Support to machining on prehardened steels and hardened steels (~ 65HRC)
		<b>MACH225 MACH225SF</b>  Sharp cutting edge reduces cutting load	
		<b>MRBTNH230 MRBTNH345</b>  Taper neck shape significantly increases tool rigidity	

Long neck ball end mill supports machining from prehardened steels to hardened steels(~ 65HRC)  
Abundant size variations with total 334 sizes

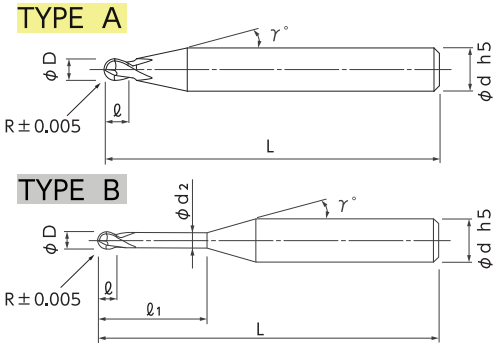

- MUGEN COATING PREMIUM for hardened steel and unique cutting edge realize excellent chipping resistance and suppress chattering to improve finishing surface.
- Support hardened steels up to 65HRC.
- Lineup to total 334 sizes.

Work Material

Prehardened Steel P	Hardened Steel H	
	40~60HRC	~65HRC

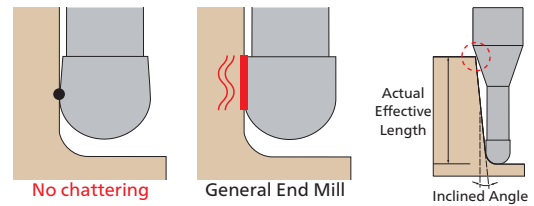

Unit [Size : mm]

Code No.	Corner Radius (R)	Under Neck Length (ℓ <sub>1</sub> )	Length of Cut (ℓ)	Type	Dia. (D)	Neck Dia. (d <sub>2</sub> )	Neck Taper Angle (γ)	Shank Dia. (d)	Overall Length (L)	Actual effective length depending on inclined angle of workpiece				
										30°	1°	1°30'	2°	3°
08-00527-00050	R0.05	0.2	0.07	B	0.1	0.085	12°	4	45	0.24	0.25	0.26	0.27	0.29
08-00527-00054		0.25	0.07	B	0.1	0.085	12°	4	45	0.29	0.30	0.31	0.33	0.36
08-00527-00051		0.3	0.07	B	0.1	0.085	12°	4	45	0.34	0.36	0.37	0.39	0.42
08-00527-00055		0.35	0.07	B	0.1	0.085	12°	4	45	0.39	0.41	0.43	0.45	0.49
08-00527-00052		0.4	0.07	B	0.1	0.085	12°	4	45	0.45	0.46	0.48	0.51	0.56
08-00527-00056		0.45	0.07	B	0.1	0.085	12°	4	45	0.50	0.52	0.54	0.57	0.62
08-00527-00053		0.5	0.07	B	0.1	0.085	12°	4	45	0.55	0.57	0.60	0.63	0.69
08-00527-00070	R0.075	0.25	0.1	B	0.15	0.13	12°	4	45	0.30	0.31	0.32	0.34	0.37
08-00527-00071		0.3	0.1	B	0.15	0.13	12°	4	45	0.35	0.37	0.38	0.40	0.43
08-00527-00076		0.35	0.1	B	0.15	0.13	12°	4	45	0.41	0.42	0.44	0.46	0.50
08-00527-00072		0.4	0.1	B	0.15	0.13	12°	4	45	0.46	0.48	0.49	0.52	0.56
08-00527-00077		0.45	0.1	B	0.15	0.13	12°	4	45	0.51	0.53	0.55	0.58	0.63
08-00527-00073		0.5	0.1	B	0.15	0.13	12°	4	45	0.56	0.58	0.61	0.64	0.70
08-00527-00074		0.6	0.1	B	0.15	0.13	12°	4	45	0.67	0.69	0.72	0.75	0.83
08-00527-00078		0.75	0.1	B	0.15	0.13	12°	4	45	0.82	0.86	0.89	0.93	1.03
08-00527-00075	1	0.1	B	0.15	0.13	12°	4	45	1.08	1.13	1.18	1.23	1.36	
08-00527-00100	R0.1	0.3	0.15	B	0.2	0.18	12°	4	45	0.35	0.36	0.38	0.39	0.42
08-00527-00110		0.4	0.15	B	0.2	0.18	12°	4	45	0.46	0.47	0.49	0.51	0.56
08-00527-00101		0.5	0.15	B	0.2	0.18	12°	4	45	0.56	0.58	0.61	0.63	0.69
08-00527-00111		0.6	0.15	B	0.2	0.18	12°	4	45	0.67	0.69	0.72	0.75	0.82
08-00527-00102		0.75	0.15	B	0.2	0.18	12°	4	45	0.82	0.85	0.89	0.93	1.02
08-00527-00112		0.85	0.15	B	0.2	0.18	12°	4	45	0.93	0.96	1.00	1.05	1.15
08-00527-00103		1	0.15	B	0.2	0.18	12°	4	45	1.08	1.13	1.18	1.23	1.35
08-00528-00103		1	0.15	B	0.2	0.18	12°	6	50	1.08	1.13	1.18	1.23	1.35
08-00527-00104		1.25	0.15	B	0.2	0.18	12°	4	45	1.34	1.40	1.46	1.53	1.68
08-00527-00105		1.5	0.15	B	0.2	0.18	12°	4	45	1.60	1.67	1.75	1.83	2.02
08-00527-00106		1.75	0.15	B	0.2	0.18	12°	4	45	1.86	1.94	2.03	2.13	2.35
08-00527-00107		2	0.15	B	0.2	0.18	12°	4	45	2.13	2.22	2.32	2.43	2.68
08-00527-00113		2.25	0.15	B	0.2	0.18	12°	4	45	2.39	2.49	2.60	2.72	3.01
08-00527-00108		2.5	0.15	B	0.2	0.18	12°	4	45	2.65	2.76	2.89	3.02	3.34
08-00527-00114		2.75	0.15	B	0.2	0.18	12°	4	45	2.91	3.03	3.17	3.32	3.68
08-00527-00109	3	0.15	B	0.2	0.18	12°	4	45	3.17	3.31	3.46	3.62	4.01	
08-00527-00164	R0.15	0.2*	0.2	A	0.3	-	12°	4	45	0.20	0.20	0.20	0.20	0.20
08-00527-00162		0.5	0.2	B	0.3	0.28	12°	4	45	0.56	0.58	0.60	0.62	0.67

How to Order

When you order, indicate MRBH230 (R)×(ℓ<sub>1</sub>)×(d). (γ) is reference value.

\* Full cutting length type (TYPE A)

## MUGEN COATING PREMIUM 2-Flute Long Neck Ball End Mill for Hardened Steel

Unit [Size : mm]

Code No.	Corner Radius (R)	Under Neck Length (ℓ1)	Length of Cut (ℓ)	Type	Dia. (D)	Neck Dia. (d2)	Neck Taper Angle (γ)	Shank Dia. (d)	Overall Length (L)	Actual effective length depending on inclined angle of workpiece				
										30°	1°	1°30'	2°	3°
08-00527-00150	R0.15	0.6	0.2	B	0.3	0.28	12°	4	45	0.66	0.69	0.71	0.74	0.81
08-00527-00163		0.75	0.2	B	0.3	0.28	12°	4	45	0.82	0.85	0.88	0.92	1.01
08-00527-00151		1	0.2	B	0.3	0.28	12°	4	45	1.08	1.12	1.17	1.22	1.34
08-00527-00152		1.25	0.2	B	0.3	0.28	12°	4	45	1.34	1.39	1.45	1.52	1.67
08-00527-00153		1.5	0.2	B	0.3	0.28	12°	4	45	1.60	1.67	1.74	1.82	2.00
08-00528-00153		1.5	0.2	B	0.3	0.28	12°	6	50	1.60	1.67	1.74	1.82	2.00
08-00527-00154		1.75	0.2	B	0.3	0.28	12°	4	45	1.86	1.94	2.02	2.12	2.33
08-00527-00155		2	0.2	B	0.3	0.28	12°	4	45	2.12	2.21	2.31	2.42	2.66
08-00527-00156		2.25	0.2	B	0.3	0.28	12°	4	45	2.38	2.48	2.59	2.71	3.00
08-00527-00157		2.5	0.2	B	0.3	0.28	12°	4	45	2.64	2.76	2.88	3.01	3.33
08-00527-00159		3	0.2	B	0.3	0.28	12°	4	45	3.17	3.30	3.45	3.61	3.99
08-00527-00160		3.5	0.2	B	0.3	0.28	12°	4	45	3.69	3.85	4.02	4.21	4.65
08-00527-00161		4	0.2	B	0.3	0.28	12°	4	45	4.21	4.39	4.59	4.81	5.32
08-00527-00165		4.5	0.2	B	0.3	0.28	12°	4	45	4.73	4.94	5.16	5.41	5.98
08-00527-00200		R0.2	0.3*	0.3	A	0.4	-	12°	4	45	0.30	0.30	0.30	0.30
08-00527-00211	0.5		0.3	B	0.4	0.37	12°	4	45	0.58	0.60	0.62	0.64	0.69
08-00527-00213	0.65		0.3	B	0.4	0.37	12°	4	45	0.74	0.76	0.79	0.82	0.89
08-00527-00201	0.8		0.3	B	0.4	0.37	12°	4	45	0.89	0.93	0.96	1.00	1.09
08-00527-00202	1		0.3	B	0.4	0.37	12°	4	45	1.10	1.14	1.19	1.24	1.35
08-00528-00202	1		0.3	B	0.4	0.37	12°	6	50	1.10	1.14	1.19	1.24	1.35
08-00527-00214	1.25		0.3	B	0.4	0.37	12°	4	45	1.36	1.42	1.47	1.54	1.68
08-00527-00203	1.5		0.3	B	0.4	0.37	12°	4	45	1.62	1.69	1.76	1.84	2.02
08-00527-00215	1.75		0.3	B	0.4	0.37	12°	4	45	1.88	1.96	2.04	2.13	2.35
08-00527-00204	2		0.3	B	0.4	0.37	12°	4	45	2.15	2.23	2.33	2.43	2.68
08-00528-00204	2		0.3	B	0.4	0.37	12°	6	50	2.15	2.23	2.33	2.43	2.68
08-00527-00216	2.25		0.3	B	0.4	0.37	12°	4	45	2.41	2.51	2.61	2.73	3.01
08-00527-00205	2.5		0.3	B	0.4	0.37	12°	4	45	2.67	2.78	2.90	3.03	3.34
08-00527-00217	2.75		0.3	B	0.4	0.37	12°	4	45	2.93	3.05	3.18	3.33	3.67
08-00527-00206	3		0.3	B	0.4	0.37	12°	4	45	3.19	3.32	3.47	3.63	4.01
08-00527-00207	3.5		0.3	B	0.4	0.37	12°	4	45	3.71	3.87	4.04	4.23	4.67
08-00527-00208	4		0.3	B	0.4	0.37	12°	4	45	4.23	4.41	4.61	4.83	5.33
08-00527-00209	4.5		0.3	B	0.4	0.37	12°	4	45	4.75	4.96	5.18	5.43	6.00
08-00527-00210	5		0.3	B	0.4	0.37	12°	4	45	5.27	5.50	5.75	6.02	6.66
08-00527-00218	5.5		0.3	B	0.4	0.37	12°	4	45	5.80	6.05	6.32	6.62	7.32
08-00527-00212	6	0.3	B	0.4	0.37	12°	4	45	6.32	6.59	6.89	7.22	7.99	
08-00527-00265	R0.25	0.35*	0.35	A	0.5	-	12°	4	45	0.35	0.35	0.35	0.35	0.35
08-00527-00266		0.5	0.35	B	0.5	0.46	12°	4	45	0.60	0.62	0.64	0.66	0.70
08-00527-00267		0.75	0.35	B	0.5	0.46	12°	4	45	0.86	0.89	0.92	0.96	1.04
08-00527-00250		1	0.35	B	0.5	0.46	12°	4	45	1.13	1.16	1.21	1.26	1.37
08-00527-00268		1.25	0.35	B	0.5	0.46	12°	4	45	1.39	1.44	1.49	1.56	1.70
08-00527-00251		1.5	0.35	B	0.5	0.46	12°	4	45	1.65	1.71	1.78	1.85	2.03
08-00527-00269		1.75	0.35	B	0.5	0.46	12°	4	45	1.91	1.98	2.06	2.15	2.36
08-00527-00252		2	0.35	B	0.5	0.46	12°	4	45	2.17	2.25	2.35	2.45	2.69
08-00527-00270		2.25	0.35	B	0.5	0.46	12°	4	45	2.43	2.53	2.63	2.75	3.03
08-00527-00253		2.5	0.35	B	0.5	0.46	12°	4	45	2.69	2.80	2.92	3.05	3.36
08-00527-00254		3	0.35	B	0.5	0.46	12°	4	45	3.21	3.34	3.49	3.65	4.02
08-00527-00255		3.5	0.35	B	0.5	0.46	12°	4	45	3.73	3.89	4.06	4.25	4.69
08-00527-00256		4	0.35	B	0.5	0.46	12°	4	45	4.25	4.43	4.63	4.85	5.35
08-00527-00257		4.5	0.35	B	0.5	0.46	12°	4	45	4.78	4.98	5.20	5.44	6.01
08-00527-00258		5	0.35	B	0.5	0.46	12°	4	45	5.30	5.52	5.77	6.04	6.68
08-00527-00259	5.5	0.35	B	0.5	0.46	12°	4	45	5.82	6.07	6.34	6.64	7.34	
08-00527-00260	6	0.35	B	0.5	0.46	12°	4	45	6.34	6.61	6.91	7.24	8.00	
08-00527-00261	7	0.35	B	0.5	0.46	12°	4	45	7.38	7.70	8.05	8.44	9.33	
08-00527-00262	8	0.35	B	0.5	0.46	12°	4	45	8.42	8.79	9.19	9.63	10.66	
08-00527-00263	9	0.35	B	0.5	0.46	12°	4	45	9.47	9.88	10.33	10.83	11.99	
08-00527-00264	10	0.35	B	0.5	0.46	12°	4	45	10.51	10.97	11.47	12.03	13.31	
08-00527-00323	R0.3	0.45*	0.45	A	0.6	-	12°	4	45	0.45	0.45	0.45	0.45	0.45
08-00527-00324		0.6	0.45	B	0.6	0.56	12°	4	45	0.71	0.72	0.75	0.77	0.82
08-00527-00325		0.8	0.45	B	0.6	0.56	12°	4	45	0.91	0.94	0.97	1.01	1.09
08-00527-00300		1	0.45	B	0.6	0.56	12°	4	45	1.12	1.16	1.20	1.25	1.35

# MRBH230

## MUGEN COATING PREMIUM 2-Flute Long Neck Ball End Mill for Hardened Steel

Unit [Size : mm]

Code No.	Corner Radius (R)	Under Neck Length ( $\ell_1$ )	Length of Cut ( $\ell_2$ )	Type	Dia. (D)	Neck Dia. (d2)	Neck Taper Angle ( $\gamma$ )	Shank Dia. (d)	Overall Length (L)	Actual effective length depending on inclined angle of workpiece				
										30°	1°	1°30'	2°	3°
08-00527-00326	R0.3	1.25	0.45	B	0.6	0.56	12°	4	45	1.38	1.43	1.49	1.55	1.68
08-00527-00301		1.5	0.45	B	0.6	0.56	12°	4	45	1.64	1.71	1.77	1.84	2.02
08-00527-00327		1.75	0.45	B	0.6	0.56	12°	4	45	1.91	1.98	2.06	2.14	2.35
08-00527-00302		2	0.45	B	0.6	0.56	12°	4	45	2.17	2.25	2.34	2.44	2.68
08-00528-00302		2	0.45	B	0.6	0.56	12°	6	50	2.17	2.25	2.34	2.44	2.68
08-00527-00328		2.25	0.45	B	0.6	0.56	12°	4	45	2.43	2.52	2.63	2.74	3.01
08-00527-00303		2.5	0.45	B	0.6	0.56	12°	4	45	2.69	2.79	2.91	3.04	3.34
08-00527-00329		2.75	0.45	B	0.6	0.56	12°	4	45	2.95	3.07	3.20	3.34	3.67
08-00527-00304		3	0.45	B	0.6	0.56	12°	4	45	3.21	3.34	3.48	3.64	4.01
08-00528-00304		3	0.45	B	0.6	0.56	12°	6	50	3.21	3.34	3.48	3.64	4.01
08-00527-00305		3.5	0.45	B	0.6	0.56	12°	4	45	3.73	3.88	4.05	4.24	4.67
08-00527-00306		4	0.45	B	0.6	0.56	12°	4	45	4.25	4.43	4.62	4.84	5.33
08-00528-00306		4	0.45	B	0.6	0.56	12°	6	50	4.25	4.43	4.62	4.84	5.33
08-00527-00321		4.5	0.45	B	0.6	0.56	12°	4	45	4.77	4.97	5.19	5.43	6.00
08-00527-00308		5	0.45	B	0.6	0.56	12°	4	45	5.29	5.52	5.76	6.03	6.66
08-00527-00322		5.5	0.45	B	0.6	0.56	12°	4	45	5.82	6.06	6.33	6.63	7.32
08-00527-00310		6	0.45	B	0.6	0.56	12°	4	45	6.34	6.61	6.90	7.23	7.99
08-00527-00311		6.5	0.45	B	0.6	0.56	12°	4	45	6.86	7.15	7.47	7.83	8.65
08-00527-00312		7	0.45	B	0.6	0.56	12°	4	45	7.38	7.70	8.04	8.43	9.31
08-00527-00313		7.5	0.45	B	0.6	0.56	12°	4	45	7.90	8.24	8.61	9.02	9.98
08-00527-00314		8	0.45	B	0.6	0.56	12°	4	45	8.42	8.79	9.18	9.62	10.64
08-00527-00316		9	0.45	B	0.6	0.56	12°	4	45	9.47	9.88	10.33	10.82	11.97
08-00527-00318		10	0.45	B	0.6	0.56	12°	4	45	10.51	10.97	11.47	12.02	13.30
08-00527-00320		12	0.45	B	0.6	0.56	12°	4	45	12.59	13.14	13.75	14.41	15.95
08-00527-00354	R0.35	0.65*	0.5	A	0.7	-	12°	4	45	0.50	0.50	0.50	0.50	0.50
08-00527-00355		1	0.5	B	0.7	0.66	12°	4	45	1.12	1.16	1.19	1.24	1.34
08-00527-00350		2	0.5	B	0.7	0.66	12°	4	45	2.16	2.25	2.33	2.43	2.66
08-00527-00351		4	0.5	B	0.7	0.66	12°	4	45	4.25	4.42	4.62	4.83	5.32
08-00527-00352		6	0.5	B	0.7	0.66	12°	4	45	6.34	6.60	6.90	7.22	7.97
08-00527-00353		8	0.5	B	0.7	0.66	12°	4	45	8.42	8.78	9.18	9.61	10.63
08-00527-00400	R0.4	0.6*	0.6	A	0.8	-	12°	4	45	0.60	0.60	0.60	0.60	0.60
08-00527-00411		1	0.6	B	0.8	0.76	12°	4	45	1.12	1.15	1.19	1.23	1.32
08-00527-00412		1.5	0.6	B	0.8	0.76	12°	4	45	1.64	1.70	1.76	1.83	1.98
08-00527-00401		2	0.6	B	0.8	0.76	12°	4	45	2.16	2.24	2.33	2.42	2.65
08-00528-00401		2	0.6	B	0.8	0.76	12°	6	50	2.16	2.24	2.33	2.42	2.65
08-00527-00413		2.5	0.6	B	0.8	0.76	12°	4	45	2.68	2.79	2.90	3.02	3.31
08-00527-00402		3	0.6	B	0.8	0.76	12°	4	45	3.20	3.33	3.47	3.62	3.97
08-00527-00414		3.5	0.6	B	0.8	0.76	12°	4	45	3.73	3.88	4.04	4.22	4.64
08-00527-00403		4	0.6	B	0.8	0.76	12°	4	45	4.25	4.42	4.61	4.82	5.30
08-00527-00415		4.5	0.6	B	0.8	0.76	12°	4	45	4.77	4.96	5.18	5.41	5.97
08-00527-00404		5	0.6	B	0.8	0.76	12°	4	45	5.29	5.51	5.75	6.01	6.63
08-00527-00405		6	0.6	B	0.8	0.76	12°	4	45	6.33	6.60	6.89	7.21	7.96
08-00527-00406		7	0.6	B	0.8	0.76	12°	4	45	7.38	7.69	8.03	8.41	9.28
08-00527-00407		8	0.6	B	0.8	0.76	12°	4	45	8.42	8.78	9.17	9.60	10.61
08-00527-00408		9	0.6	B	0.8	0.76	12°	4	45	9.46	9.87	10.31	10.80	11.94
08-00527-00409		10	0.6	B	0.8	0.76	12°	4	45	10.50	10.96	11.45	12.00	13.26
08-00527-00410		12	0.6	B	0.8	0.76	12°	4	45	12.59	13.14	13.73	14.39	15.92
08-00527-00416		16	0.6	B	0.8	0.76	12°	4	50	16.76	17.49	18.29	19.18	21.23
08-00527-00454	R0.45	0.65*	0.65	A	0.9	-	12°	4	45	0.65	0.65	0.65	0.65	0.65
08-00527-00455		1	0.65	B	0.9	0.86	12°	4	45	1.12	1.15	1.18	1.22	1.30
08-00527-00450		2	0.65	B	0.9	0.86	12°	4	45	2.16	2.24	2.32	2.41	2.63
08-00527-00451		4	0.65	B	0.9	0.86	12°	4	45	4.25	4.42	4.60	4.81	5.29
08-00527-00452		6	0.65	B	0.9	0.86	12°	4	45	6.33	6.59	6.88	7.20	7.94
08-00527-00453		8	0.65	B	0.9	0.86	12°	4	45	8.42	8.77	9.16	9.59	10.59
08-00527-00517	R0.5	0.75*	0.75	A	1	-	12°	4	45	0.75	0.75	0.75	0.75	0.75
08-00527-00518		1	0.75	B	1	0.95	12°	4	45	1.14	1.17	1.20	1.24	1.32
08-00527-00519		1.5	0.75	B	1	0.95	12°	4	45	1.66	1.71	1.77	1.83	1.98
08-00527-00500		2	0.75	B	1	0.95	12°	4	45	2.18	2.26	2.34	2.43	2.65
08-00527-00514		2.5	0.75	B	1	0.95	12°	4	45	2.70	2.80	2.91	3.03	3.31
08-00527-00501		3	0.75	B	1	0.95	12°	4	45	3.22	3.35	3.48	3.63	3.97

### How to Order

When you order, indicate MRBH230 (R) $\times$ ( $\ell_1$ ) $\times$ (d). ( $\gamma$ ) is reference value.

\* Full cutting length type (TYPE A)



## MUGEN COATING PREMIUM 2-Flute Long Neck Ball End Mill for Hardened Steel

Unit [Size : mm]

Code No.	Corner Radius (R)	Under Neck Length ( $\ell_1$ )	Length of Cut ( $\ell_2$ )	Type	Dia. (D)	Neck Dia. (d2)	Neck Taper Angle ( $\gamma$ )	Shank Dia. (d)	Overall Length (L)	Actual effective length depending on inclined angle of workpiece				
										30°	1°	1°30'	2°	3°
08-00528-00501	R0.5	3	0.75	B	1	0.95	12°	6	50	3.22	3.35	3.48	3.63	3.97
08-00527-00520		3.5	0.75	B	1	0.95	12°	4	45	3.75	3.89	4.05	4.23	4.64
08-00527-00502		4	0.75	B	1	0.95	12°	4	45	4.27	4.44	4.62	4.83	5.30
08-00528-00502		4	0.75	B	1	0.95	12°	6	50	4.27	4.44	4.62	4.83	5.30
08-00527-00521		4.5	0.75	B	1	0.95	12°	4	45	4.79	4.98	5.19	5.42	5.96
08-00527-00503		5	0.75	B	1	0.95	12°	4	45	5.31	5.53	5.76	6.02	6.63
08-00528-00503		5	0.75	B	1	0.95	12°	6	50	5.31	5.53	5.76	6.02	6.63
08-00527-00504		6	0.75	B	1	0.95	12°	4	45	6.35	6.62	6.90	7.22	7.96
08-00528-00504		6	0.75	B	1	0.95	12°	6	50	6.35	6.62	6.90	7.22	7.96
08-00527-00505		7	0.75	B	1	0.95	12°	4	45	7.40	7.71	8.04	8.42	9.28
08-00528-00505		7	0.75	B	1	0.95	12°	6	50	7.40	7.71	8.04	8.42	9.28
08-00527-00506		8	0.75	B	1	0.95	12°	4	45	8.44	8.79	9.18	9.61	10.61
08-00528-00506		8	0.75	B	1	0.95	12°	6	50	8.44	8.79	9.18	9.61	10.61
08-00527-00507		9	0.75	B	1	0.95	12°	4	45	9.48	9.88	10.32	10.81	11.94
08-00527-00508		10	0.75	B	1	0.95	12°	4	45	10.52	10.97	11.46	12.01	13.26
08-00528-00508		10	0.75	B	1	0.95	12°	6	50	10.52	10.97	11.46	12.01	13.26
08-00527-00509		12	0.75	B	1	0.95	12°	4	45	12.61	13.15	13.75	14.40	15.92
08-00527-00515		13	0.75	B	1	0.95	12°	4	45	13.65	14.24	14.89	15.59	17.25
08-00527-00510		14	0.75	B	1	0.95	12°	4	50	14.70	15.33	16.03	16.79	18.57
08-00527-00511		16	0.75	B	1	0.95	12°	4	50	16.78	17.51	18.31	19.18	21.23
08-00527-00512		18	0.75	B	1	0.95	12°	4	55	18.87	19.69	20.59	21.58	23.88
08-00527-00513		20	0.75	B	1	0.95	12°	4	55	20.95	21.87	22.87	23.97	26.54
08-00528-00516	22	0.75	B	1	0.95	12°	6	60	23.04	24.05	25.15	26.36	29.19	
08-00527-00608	R0.6	1.2	0.9	B	1.2	1.15	12°	4	45	1.34	1.38	1.41	1.46	1.55
08-00527-00600		2.4	0.9	B	1.2	1.15	12°	4	45	2.59	2.68	2.78	2.89	3.15
08-00527-00601		4	0.9	B	1.2	1.15	12°	4	45	4.26	4.43	4.61	4.81	5.27
08-00527-00602		6	0.9	B	1.2	1.15	12°	4	45	6.35	6.61	6.89	7.20	7.92
08-00527-00603		8	0.9	B	1.2	1.15	12°	4	45	8.43	8.79	9.17	9.59	10.58
08-00527-00604		10	0.9	B	1.2	1.15	12°	4	45	10.52	10.96	11.45	11.99	13.23
08-00527-00605		12	0.9	B	1.2	1.15	12°	4	45	12.61	13.14	13.73	14.38	15.89
08-00527-00606		14	0.9	B	1.2	1.15	12°	4	50	14.69	15.32	16.01	16.77	18.54
08-00527-00607	16	0.9	B	1.2	1.15	12°	4	50	16.78	17.50	18.29	19.17	21.20	
08-00527-00703	R0.7	2	1	B	1.4	1.35	12°	4	45	2.17	2.24	2.31	2.39	2.58
08-00527-00704		4	1	B	1.4	1.35	12°	4	45	4.26	4.42	4.59	4.79	5.24
08-00527-00705		6	1	B	1.4	1.35	12°	4	45	6.34	6.60	6.88	7.18	7.89
08-00527-00700		8	1	B	1.4	1.35	12°	4	45	8.43	8.78	9.16	9.57	10.55
08-00527-00701		12	1	B	1.4	1.35	12°	4	50	12.60	13.13	13.72	14.36	15.85
08-00527-00702		16	1	B	1.4	1.35	12°	4	50	16.77	17.49	18.28	19.15	21.16
08-00527-00765	R0.75	2	1.1	B	1.5	1.45	12°	4	45	2.17	2.24	2.31	2.38	2.57
08-00527-00750		3	1.1	B	1.5	1.45	12°	4	45	3.21	3.33	3.45	3.58	3.89
08-00527-00751		4	1.1	B	1.5	1.45	12°	4	45	4.26	4.41	4.59	4.78	5.22
08-00527-00752		5	1.1	B	1.5	1.45	12°	4	45	5.30	5.50	5.73	5.97	6.55
08-00527-00753		6	1.1	B	1.5	1.45	12°	4	45	6.34	6.59	6.87	7.17	7.88
08-00528-00753		6	1.1	B	1.5	1.45	12°	6	50	6.34	6.59	6.87	7.17	7.88
08-00527-00755		8	1.1	B	1.5	1.45	12°	4	45	8.43	8.77	9.15	9.56	10.53
08-00528-00755		8	1.1	B	1.5	1.45	12°	6	50	8.43	8.77	9.15	9.56	10.53
08-00527-00757		10	1.1	B	1.5	1.45	12°	4	45	10.51	10.95	11.43	11.96	13.18
08-00527-00758		12	1.1	B	1.5	1.45	12°	4	45	12.60	13.13	13.71	14.35	15.84
08-00527-00759		14	1.1	B	1.5	1.45	12°	4	50	14.69	15.31	15.99	16.74	18.49
08-00527-00760		16	1.1	B	1.5	1.45	12°	4	50	16.77	17.49	18.27	19.14	21.15
08-00527-00761		18	1.1	B	1.5	1.45	12°	4	55	18.86	19.67	20.55	21.53	23.80
08-00527-00762		20	1.1	B	1.5	1.45	12°	4	55	20.94	21.85	22.84	23.92	Free
08-00527-00763		22	1.1	B	1.5	1.45	12°	4	60	23.03	24.02	25.12	26.32	Free
08-00527-00766	25	1.1	B	1.5	1.45	12°	4	65	26.16	27.29	28.54	29.91	Free	
08-00527-00764	30	1.1	B	1.5	1.45	12°	4	70	31.37	32.74	34.24	35.89	Free	
08-00527-00800	R0.8	2	1.2	B	1.6	1.55	12°	4	45	2.17	2.23	2.30	2.37	2.55
08-00527-00801		4	1.2	B	1.6	1.55	12°	4	45	4.25	4.41	4.58	4.77	5.21
08-00527-00802		6	1.2	B	1.6	1.55	12°	4	45	6.34	6.59	6.86	7.16	7.86
08-00527-00803		8	1.2	B	1.6	1.55	12°	4	45	8.43	8.77	9.14	9.55	10.51
08-00527-00805		12	1.2	B	1.6	1.55	12°	4	45	12.60	13.13	13.70	14.34	15.82

# MRBH230

## MUGEN COATING PREMIUM 2-Flute Long Neck Ball End Mill for Hardened Steel

Unit [Size : mm]

Code No.	Corner Radius (R)	Under Neck Length ( $\ell_1$ )	Length of Cut ( $\ell_2$ )	Type	Dia. (D)	Neck Dia. (d2)	Neck Taper Angle ( $\gamma$ )	Shank Dia. (d)	Overall Length (L)	Actual effective length depending on inclined angle of workpiece					
										30°	1°	1°30'	2°	3°	
08-00527-00807	R0.8	16	1.2	B	1.6	1.55	12°	4	50	16.77	17.48	18.27	19.13	21.13	
08-00527-00809		20	1.2	B	1.6	1.55	12°	4	55	20.94	21.84	22.83	23.91	Free	
08-00527-00901	R0.9	3	1.3	B	1.8	1.74	12°	4	45	3.23	3.34	3.45	3.58	3.88	
08-00527-00902		4	1.3	B	1.8	1.74	12°	4	45	4.28	4.43	4.59	4.78	5.20	
08-00527-00903		6	1.3	B	1.8	1.74	12°	4	45	6.36	6.61	6.87	7.17	7.86	
08-00527-00904		8	1.3	B	1.8	1.74	12°	4	45	8.45	8.78	9.16	9.56	10.51	
08-00527-00905		10	1.3	B	1.8	1.74	12°	4	45	10.53	10.96	11.44	11.96	13.17	
08-00527-00906		12	1.3	B	1.8	1.74	12°	4	45	12.62	13.14	13.72	14.35	15.82	
08-00527-00907		16	1.3	B	1.8	1.74	12°	4	50	16.79	17.50	18.28	19.14	21.13	
08-00527-00908		18	1.3	B	1.8	1.74	12°	4	55	18.87	19.68	20.56	21.53	Free	
08-00527-00909		20	1.3	B	1.8	1.74	12°	4	55	20.96	21.86	22.84	23.92	Free	
08-00527-00910		22	1.3	B	1.8	1.74	12°	4	60	23.05	24.04	25.12	26.31	Free	
08-00527-00911		25	1.3	B	1.8	1.74	12°	4	65	26.17	27.31	28.54	29.90	Free	
08-00527-00912		30	1.3	B	1.8	1.74	12°	4	70	31.39	32.75	34.25	Free	Free	
08-00527-01000	R1	2	1.5	B	2	1.94	12°	4	45	2.19	2.24	2.30	2.36	2.52	
08-00527-01001		3	1.5	B	2	1.94	12°	4	45	3.23	3.33	3.44	3.56	3.85	
08-00528-01001		3	1.5	B	2	1.94	12°	6	50	3.23	3.33	3.44	3.56	3.85	
08-00527-01002		4	1.5	B	2	1.94	12°	4	45	4.27	4.42	4.58	4.76	5.17	
08-00528-01002		4	1.5	B	2	1.94	12°	6	50	4.27	4.42	4.58	4.76	5.17	
08-00527-01004		6	1.5	B	2	1.94	12°	4	45	6.36	6.60	6.86	7.15	7.83	
08-00528-01004		6	1.5	B	2	1.94	12°	6	50	6.36	6.60	6.86	7.15	7.83	
08-00527-01006		8	1.5	B	2	1.94	12°	4	45	8.44	8.78	9.14	9.54	10.48	
08-00528-01006		8	1.5	B	2	1.94	12°	6	50	8.44	8.78	9.14	9.54	10.48	
08-00527-01008		10	1.5	B	2	1.94	12°	4	45	10.53	10.95	11.42	11.94	13.14	
08-00528-01008		10	1.5	B	2	1.94	12°	6	50	10.53	10.95	11.42	11.94	13.14	
08-00527-01010		12	1.5	B	2	1.94	12°	4	45	12.61	13.13	13.70	14.33	15.79	
08-00528-01010		12	1.5	B	2	1.94	12°	6	50	12.61	13.13	13.70	14.33	15.79	
08-00527-01020		13	1.5	B	2	1.94	12°	4	45	13.66	14.22	14.84	15.53	17.12	
08-00527-01011		14	1.5	B	2	1.94	12°	4	50	14.70	15.31	15.98	16.72	18.45	
08-00528-01011		14	1.5	B	2	1.94	12°	6	50	14.70	15.31	15.98	16.72	18.45	
08-00527-01012		16	1.5	B	2	1.94	12°	4	50	16.78	17.49	18.27	19.12	Free	
08-00528-01012		16	1.5	B	2	1.94	12°	6	60	16.78	17.49	18.27	19.12	21.10	
08-00527-01013		18	1.5	B	2	1.94	12°	4	55	18.87	19.67	20.55	21.51	Free	
08-00528-01013		18	1.5	B	2	1.94	12°	6	60	18.87	19.67	20.55	21.51	23.75	
08-00527-01014		20	1.5	B	2	1.94	12°	4	55	20.96	21.85	22.83	23.90	Free	
08-00528-01014		20	1.5	B	2	1.94	12°	6	60	20.96	21.85	22.83	23.90	26.41	
08-00527-01015		22	1.5	B	2	1.94	12°	4	60	23.04	24.03	25.11	26.30	Free	
08-00527-01016		25	1.5	B	2	1.94	12°	4	65	26.17	27.30	28.53	Free	Free	
08-00528-01016		25	1.5	B	2	1.94	12°	6	65	26.17	27.30	28.53	29.89	33.04	
08-00527-01021		27	1.5	B	2	1.94	12°	4	70	28.26	29.48	30.81	Free	Free	
08-00527-01017		30	1.5	B	2	1.94	12°	4	70	31.38	32.74	34.23	Free	Free	
08-00528-01017		30	1.5	B	2	1.94	12°	6	70	31.38	32.74	34.23	35.87	Free	
08-00527-01022		32	1.5	B	2	1.94	12°	4	70	33.47	34.92	36.51	Free	Free	
08-00527-01018		35	1.5	B	2	1.94	12°	4	70	36.60	38.19	Free	Free	Free	
08-00528-01018		35	1.5	B	2	1.94	12°	6	80	36.60	38.19	39.93	41.85	Free	
08-00527-01019		40	1.5	B	2	1.94	12°	4	90	41.81	43.64	Free	Free	Free	
08-00528-01019		40	1.5	B	2	1.94	12°	6	90	41.81	43.64	45.64	47.83	Free	
08-00527-01258		R1.25	4	2.3	B	2.5	2.4	12°	4	45	4.36	4.50	4.65	4.82	5.22
08-00527-01250			6	2.3	B	2.5	2.4	12°	4	45	6.44	6.68	6.93	7.21	7.87
08-00527-01251			8	2.3	B	2.5	2.4	12°	4	45	8.53	8.86	9.21	9.61	10.53
08-00527-01252			10	2.3	B	2.5	2.4	12°	4	45	10.62	11.04	11.49	12.00	13.18
08-00527-01253			15	2.3	B	2.5	2.4	12°	4	50	15.83	16.48	17.20	17.98	Free
08-00527-01254			20	2.3	B	2.5	2.4	12°	4	55	21.04	21.93	22.90	Free	Free
08-00527-01255			25	2.3	B	2.5	2.4	12°	4	65	26.26	27.38	28.60	Free	Free
08-00527-01256	30		2.3	B	2.5	2.4	12°	4	70	31.47	32.82	Free	Free	Free	
08-00527-01257	35	2.3	B	2.5	2.4	12°	4	70	36.69	38.27	Free	Free	Free		
08-00527-01501	R1.5	6	2.5	B	3	2.85	12°	6	60	6.56	6.78	7.03	7.31	7.95	
08-00527-01502		8	2.5	B	3	2.85	12°	6	60	8.64	8.96	9.31	9.70	10.60	
08-00527-01503		10	2.5	B	3	2.85	12°	6	60	10.73	11.14	11.59	12.09	13.26	
08-00527-01504		12	2.5	B	3	2.85	12°	6	60	12.81	13.32	13.88	14.49	15.91	

### How to Order

When you order, indicate MRBH230 (R) $\times$ ( $\ell_1$ ) $\times$ (d). ( $\gamma$ ) is reference value.

※ Full cutting length type (TYPE A)



## MUGEN COATING PREMIUM 2-Flute Long Neck Ball End Mill for Hardened Steel

Unit [Size : mm]

Code No.	Corner Radius (R)	Under Neck Length (L1)	Length of Cut (L)	Type	Dia. (D)	Neck Dia. (d2)	Neck Taper Angle ( $\gamma$ )	Shank Dia. (d)	Overall Length (L)	Actual effective length depending on inclined angle of workpiece					
										30°	1°	1°30'	2°	3°	
08-00527-01505	R1.5	14	2.5	B	3	2.85	12°	6	60	14.90	15.50	16.16	16.88	18.57	
08-00527-01506		16	2.5	B	3	2.85	12°	6	60	16.98	17.68	18.44	19.27	21.22	
08-00527-01507		18	2.5	B	3	2.85	12°	6	60	19.07	19.86	20.72	21.67	23.88	
08-00527-01508		20	2.5	B	3	2.85	12°	6	65	21.16	22.04	23.00	24.06	26.53	
08-00527-01513		22	2.5	B	3	2.85	12°	6	65	23.24	24.21	25.28	26.45	29.18	
08-00527-01509		25	2.5	B	3	2.85	12°	6	65	26.37	27.48	28.70	30.04	Free	
08-00527-01514		27	2.5	B	3	2.85	12°	6	70	28.46	29.66	30.98	32.44	Free	
08-00527-01510		30	2.5	B	3	2.85	12°	6	70	31.58	32.93	34.40	36.03	Free	
08-00527-01511		35	2.5	B	3	2.85	12°	6	80	36.80	38.38	40.11	42.01	Free	
08-00527-01512		40	2.5	B	3	2.85	12°	6	90	42.01	43.83	45.81	Free	Free	
08-00527-01757	R1.75	5	2.8	B	3.5	3.35	12°	6	60	5.50	5.67	5.86	6.06	6.54	
08-00527-01758		10	2.8	B	3.5	3.35	12°	6	60	10.72	11.12	11.56	12.05	13.18	
08-00527-01750		15	2.8	B	3.5	3.35	12°	6	60	15.93	16.57	17.26	18.03	19.81	
08-00527-01754		20	2.8	B	3.5	3.35	12°	6	65	21.14	22.01	22.96	24.01	Free	
08-00527-01751		25	2.8	B	3.5	3.35	12°	6	65	26.36	27.46	28.67	29.99	Free	
08-00527-01755		30	2.8	B	3.5	3.35	12°	6	70	31.57	32.91	34.37	35.98	Free	
08-00527-01752		35	2.8	B	3.5	3.35	12°	6	80	36.79	38.36	40.07	Free	Free	
08-00527-01756		40	2.8	B	3.5	3.35	12°	6	90	42.00	43.80	45.77	Free	Free	
08-00527-01753		45	2.8	B	3.5	3.35	12°	6	90	47.22	49.25	Free	Free	Free	
08-00527-02015	R2	6	3	B	4	3.8	-	4	65	Free	Free	Free	Free	Free	
08-00527-02016		6	3	B	4	3.8	12°	6	65	6.66	6.87	7.10	7.35	7.95	
08-00527-02000		8	3	B	4	3.8	-	4	65	Free	Free	Free	Free	Free	
08-00527-02001		8	3	B	4	3.8	12°	6	65	8.74	9.05	9.38	9.74	10.60	
08-00527-02017		10	3	B	4	3.8	-	4	65	Free	Free	Free	Free	Free	
08-00527-02002		10	3	B	4	3.8	12°	6	65	10.83	11.22	11.66	12.14	13.25	
08-00527-02003		12	3	B	4	3.8	12°	6	65	12.91	13.40	13.94	14.53	15.91	
08-00527-02101		14	3	B	4	3.8	12°	6	65	15.00	15.58	16.22	16.92	18.56	
08-00527-02004		15	3	B	4	3.8	12°	6	65	16.04	16.67	17.36	18.12	19.89	
08-00527-02005		16	3	B	4	3.8	12°	6	65	17.09	17.76	18.50	19.32	Free	
08-00527-02018		18	3	B	4	3.8	12°	6	65	19.17	19.94	20.78	21.71	Free	
08-00527-02006		20	3	B	4	3.8	12°	6	65	21.26	22.12	23.06	24.10	Free	
08-00527-02007		22	3	B	4	3.8	12°	6	70	23.34	24.30	25.35	26.50	Free	
08-00527-02008		25	3	B	4	3.8	12°	6	70	26.47	27.57	28.77	30.09	Free	
08-00527-02009		27	3	B	4	3.8	12°	6	70	28.56	29.75	31.05	Free	Free	
08-00527-02010		30	3	B	4	3.8	12°	6	70	31.68	33.01	34.47	Free	Free	
08-00527-02011		35	3	B	4	3.8	12°	6	80	36.90	38.46	Free	Free	Free	
08-00527-02012		40	3	B	4	3.8	12°	6	85	42.11	43.91	Free	Free	Free	
08-00527-02013		45	3	B	4	3.8	12°	6	90	47.33	49.36	Free	Free	Free	
08-00527-02014		50	3	B	4	3.8	12°	6	100	52.54	54.80	Free	Free	Free	
08-00527-02500		R2.5	10	3.5	B	5	4.8	12°	6	70	10.81	11.18	11.59	12.04	Free
08-00527-02501			15	3.5	B	5	4.8	12°	6	70	16.02	16.63	17.29	Free	Free
08-00527-02502			20	3.5	B	5	4.8	12°	6	70	21.24	22.08	Free	Free	Free
08-00527-02503			25	3.5	B	5	4.8	12°	6	70	26.45	27.52	Free	Free	Free
08-00527-02504			30	3.5	B	5	4.8	12°	6	80	31.66	Free	Free	Free	Free
08-00527-02505	35		3.5	B	5	4.8	12°	6	80	36.88	Free	Free	Free	Free	
08-00527-02506	40		3.5	B	5	4.8	12°	6	90	42.09	Free	Free	Free	Free	
08-00527-02507	45		3.5	B	5	4.8	12°	6	100	47.31	Free	Free	Free	Free	
08-00527-02508	50		3.5	B	5	4.8	12°	6	100	52.52	Free	Free	Free	Free	
08-00527-03009	R3		8	6	B	6	5.7	-	6	70	Free	Free	Free	Free	Free
08-00527-03000		10	6	B	6	5.7	-	6	70	Free	Free	Free	Free	Free	
08-00527-03010		12	6	B	6	5.7	-	6	70	Free	Free	Free	Free	Free	
08-00527-03001		15	6	B	6	5.7	-	6	70	Free	Free	Free	Free	Free	
08-00527-03011		18	6	B	6	5.7	-	6	70	Free	Free	Free	Free	Free	
08-00527-03002		20	6	B	6	5.7	-	6	70	Free	Free	Free	Free	Free	
08-00527-03003		25	6	B	6	5.7	-	6	70	Free	Free	Free	Free	Free	
08-00527-03004		30	6	B	6	5.7	-	6	80	Free	Free	Free	Free	Free	
08-00527-03007		35	6	B	6	5.7	-	6	85	Free	Free	Free	Free	Free	
08-00527-03005		40	6	B	6	5.7	-	6	90	Free	Free	Free	Free	Free	
08-00527-03006		50	6	B	6	5.7	-	6	120	Free	Free	Free	Free	Free	
08-00527-03008		60	6	B	6	5.7	-	6	120	Free	Free	Free	Free	Free	

## Recommended Conditions (Metric)

Work Material			Hardened Steels SKD61·STAVAX·HPM-38 (~52HRC)				Hardened Steels SKD11 (~62HRC)				High Speed Steels SKH (~65HRC)			
Corner Radius	Under Neck Length	L/D	Depth of Cut		Feed	Spindle Speed	Depth of Cut		Feed	Spindle Speed	Depth of Cut		Feed	Spindle Speed
			a <sub>p</sub> mm	a <sub>e</sub> mm	mm/min	min <sup>-1</sup>	a <sub>p</sub> mm	a <sub>e</sub> mm	mm/min	min <sup>-1</sup>	a <sub>p</sub> mm	a <sub>e</sub> mm	mm/min	min <sup>-1</sup>
0.05	0.2	2.0	0.003	0.005	120	40,000	0.002	0.005	100	40,000	0.002	0.003	70	40,000
	0.25	2.5	0.003	0.005	110	40,000	0.002	0.005	80	40,000	0.002	0.003	50	40,000
	0.3	3.0	0.003	0.005	100	40,000	0.002	0.005	70	40,000	0.002	0.003	50	40,000
	0.35	3.5	0.002	0.005	100	40,000	0.001	0.005	70	40,000	0.001	0.003	50	40,000
	0.4	4.0	0.002	0.005	90	40,000	0.001	0.005	70	40,000	0.001	0.003	50	40,000
	0.45	4.5	0.002	0.003	80	40,000	0.001	0.003	60	40,000	0.001	0.002	40	40,000
	0.5	5.0	0.002	0.003	70	40,000	0.001	0.003	50	40,000	0.001	0.002	30	40,000
0.075	0.25	1.7	0.003	0.005	200	40,000	0.002	0.005	160	40,000	0.002	0.003	120	40,000
	0.3	2.0	0.003	0.005	180	40,000	0.002	0.005	150	40,000	0.002	0.003	100	40,000
	0.35	2.3	0.003	0.005	180	40,000	0.002	0.005	150	40,000	0.002	0.003	100	40,000
	0.4	2.6	0.003	0.005	150	40,000	0.002	0.005	120	40,000	0.002	0.003	70	40,000
	0.45	3.0	0.003	0.005	150	40,000	0.002	0.005	120	40,000	0.002	0.003	70	40,000
	0.5	3.3	0.003	0.005	150	40,000	0.002	0.005	120	40,000	0.002	0.003	70	40,000
	0.6	4.0	0.002	0.003	120	40,000	0.001	0.003	100	40,000	0.001	0.002	50	40,000
0.1	0.75	5.0	0.002	0.003	100	40,000	0.001	0.003	80	40,000	0.001	0.002	40	40,000
	1	6.7	0.002	0.003	70	40,000	0.001	0.003	50	40,000	0.001	0.002	30	40,000
	0.3	1.5	0.01	0.01	350	40,000	0.006	0.005	300	40,000	0.003	0.003	200	40,000
	0.4	2.0	0.008	0.01	330	40,000	0.005	0.005	290	40,000	0.003	0.003	200	40,000
	0.5	2.5	0.008	0.01	320	40,000	0.005	0.005	280	40,000	0.003	0.003	180	40,000
	0.6	3.0	0.005	0.01	300	40,000	0.003	0.005	250	40,000	0.002	0.003	160	40,000
	0.75	3.8	0.005	0.01	280	40,000	0.003	0.005	200	40,000	0.002	0.003	150	40,000
	0.85	4.3	0.003	0.005	260	40,000	0.002	0.005	180	40,000	0.001	0.003	130	40,000
	1	5.0	0.003	0.005	250	40,000	0.002	0.003	160	40,000	0.001	0.002	120	40,000
	1.25	6.3	0.003	0.005	180	40,000	0.002	0.003	140	40,000	0.001	0.002	100	40,000
	1.5	7.5	0.003	0.005	150	40,000	0.002	0.003	120	40,000	0.001	0.002	80	40,000
	1.75	8.8	0.002	0.003	120	40,000	0.001	0.002	100	40,000	0.001	0.002	60	40,000
	2	10.0	0.002	0.003	100	40,000	0.001	0.002	80	40,000	0.001	0.001	50	40,000
0.15	2.25	11.3	0.001	0.002	80	40,000	0.001	0.001	70	40,000	0.001	0.001	45	40,000
	2.5	12.5	0.001	0.002	70	40,000	0.001	0.001	60	40,000	0.001	0.001	40	40,000
	2.75	13.8	0.001	0.001	60	40,000	0.001	0.001	50	40,000	0.001	0.001	35	40,000
	3	15.0	0.001	0.001	50	40,000	0.001	0.001	40	40,000	0.001	0.001	30	40,000
	-	-	0.01	0.015	450	40,000	0.007	0.01	380	40,000	0.003	0.005	320	40,000
	0.5	1.6	0.01	0.015	350	40,000	0.007	0.01	300	40,000	0.003	0.005	280	40,000
	0.6	2.0	0.007	0.01	350	40,000	0.005	0.007	300	40,000	0.003	0.005	250	40,000
	0.75	2.5	0.007	0.01	330	40,000	0.005	0.007	280	40,000	0.003	0.005	230	40,000
	1	3.3	0.007	0.01	320	40,000	0.005	0.007	250	40,000	0.003	0.005	200	40,000
	1.25	4.2	0.005	0.007	280	40,000	0.003	0.005	200	40,000	0.002	0.003	160	40,000
	1.5	5.0	0.005	0.007	230	40,000	0.003	0.005	180	40,000	0.002	0.003	120	40,000
	1.75	5.8	0.003	0.005	180	40,000	0.002	0.003	150	40,000	0.002	0.002	100	40,000
	2	6.6	0.003	0.005	150	40,000	0.002	0.003	120	40,000	0.002	0.002	90	40,000
0.2	2.25	7.5	0.002	0.003	120	40,000	0.001	0.002	100	40,000	0.001	0.001	80	40,000
	2.5	8.3	0.002	0.003	100	40,000	0.001	0.002	80	40,000	0.001	0.001	70	40,000
	3	10.0	0.001	0.003	80	40,000	0.001	0.002	70	40,000	0.001	0.001	60	40,000
	3.5	11.7	0.001	0.002	70	40,000	0.001	0.001	60	40,000	0.001	0.001	50	40,000
	4	13.3	0.001	0.002	60	40,000	0.001	0.001	50	40,000	0.001	0.001	40	40,000
	4.5	15.0	0.001	0.001	50	40,000	0.001	0.001	40	40,000	0.001	0.001	30	40,000
	-	-	0.03	0.05	800	40,000	0.03	0.03	720	40,000	0.009	0.02	580	40,000
	0.5	1.3	0.03	0.05	800	40,000	0.03	0.03	720	40,000	0.009	0.02	580	40,000
	0.65	1.6	0.025	0.05	800	40,000	0.025	0.03	720	40,000	0.009	0.02	580	40,000
	0.8	2.0	0.02	0.05	800	40,000	0.02	0.03	720	40,000	0.008	0.02	580	40,000

## Recommended Conditions (Metric)

Work Material			Hardened Steels SKD61·STAVAX·HPM-38 (~52HRC)				Hardened Steels SKD11 (~62HRC)				High Speed Steels SKH (~65HRC)			
Corner Radius	Under Neck Length	L/D	Depth of Cut		Feed	Spindle Speed	Depth of Cut		Feed	Spindle Speed	Depth of Cut		Feed	Spindle Speed
			a <sub>p</sub> mm	a <sub>e</sub> mm	mm/min	min <sup>-1</sup>	a <sub>p</sub> mm	a <sub>e</sub> mm	mm/min	min <sup>-1</sup>	a <sub>p</sub> mm	a <sub>e</sub> mm	mm/min	min <sup>-1</sup>
0.2	2.5	6.3	0.007	0.01	420	40,000	0.005	0.007	300	40,000	0.003	0.005	260	40,000
	2.75	6.9	0.007	0.01	350	40,000	0.005	0.007	280	40,000	0.003	0.005	220	40,000
	3	7.5	0.007	0.01	300	40,000	0.005	0.007	240	40,000	0.003	0.005	200	40,000
	3.5	8.8	0.005	0.007	230	40,000	0.003	0.005	160	40,000	0.002	0.003	120	40,000
	4	10.0	0.005	0.005	160	30,000	0.003	0.003	120	30,000	0.002	0.003	90	30,000
	4.5	11.3	0.003	0.005	100	30,000	0.002	0.003	80	30,000	0.001	0.002	60	30,000
	5	12.5	0.002	0.003	70	30,000	0.001	0.002	50	30,000	0.001	0.002	40	30,000
	5.5	13.8	0.001	0.002	60	30,000	0.001	0.002	40	30,000	0.001	0.001	40	30,000
0.25	6	15.0	0.001	0.002	50	30,000	0.001	0.001	40	30,000	0.001	0.001	30	30,000
	-	-	0.04	0.07	1,000	40,000	0.03	0.05	860	40,000	0.015	0.03	650	40,000
	0.5	1.0	0.04	0.07	1,000	40,000	0.03	0.04	860	40,000	0.015	0.03	650	40,000
	0.75	1.5	0.03	0.06	1,000	40,000	0.025	0.03	860	40,000	0.012	0.02	650	40,000
	1	2.0	0.03	0.05	1,000	40,000	0.02	0.03	860	40,000	0.01	0.02	650	40,000
	1.25	2.5	0.025	0.05	920	40,000	0.02	0.03	780	40,000	0.01	0.02	580	40,000
	1.5	3.0	0.02	0.05	850	40,000	0.01	0.03	720	40,000	0.007	0.02	520	40,000
	1.75	3.5	0.02	0.04	800	40,000	0.01	0.03	680	40,000	0.007	0.02	480	40,000
	2	4.0	0.02	0.03	720	40,000	0.01	0.02	650	40,000	0.007	0.01	400	40,000
	2.25	4.5	0.015	0.03	650	40,000	0.007	0.02	580	40,000	0.005	0.01	380	40,000
	2.5	5.0	0.01	0.02	600	40,000	0.007	0.01	530	40,000	0.005	0.007	360	40,000
	3	6.0	0.01	0.02	500	40,000	0.007	0.01	420	40,000	0.005	0.007	320	40,000
	3.5	7.0	0.007	0.01	420	40,000	0.005	0.007	360	40,000	0.003	0.005	280	40,000
	4	8.0	0.007	0.01	350	40,000	0.005	0.007	300	40,000	0.003	0.005	260	40,000
	4.5	9.0	0.005	0.005	300	40,000	0.003	0.003	260	40,000	0.002	0.003	220	40,000
	5	10.0	0.005	0.005	240	33,000	0.003	0.003	200	33,000	0.002	0.003	180	33,000
	5.5	11.0	0.003	0.005	200	30,000	0.002	0.003	160	30,000	0.001	0.002	120	30,000
	6	12.0	0.002	0.003	120	30,000	0.001	0.002	80	30,000	0.001	0.002	70	30,000
	7	14.0	0.002	0.002	90	30,000	0.001	0.002	70	30,000	0.001	0.002	60	30,000
	8	16.0	0.002	0.002	75	30,000	0.001	0.002	60	30,000	0.001	0.002	50	30,000
9	18.0	0.001	0.002	60	25,000	0.001	0.002	50	25,000	0.001	0.001	35	22,000	
10	20.0	0.001	0.002	40	20,000	0.001	0.002	30	20,000	0.001	0.001	20	20,000	
0.3	-	-	0.05	0.1	1,400	40,000	0.03	0.08	1,000	40,000	0.02	0.05	720	35,000
	0.6	1.0	0.05	0.1	1,400	40,000	0.03	0.08	1,000	40,000	0.02	0.05	720	35,000
	0.8	1.3	0.05	0.1	1,400	40,000	0.03	0.08	1,000	40,000	0.02	0.05	720	35,000
	1	1.7	0.05	0.1	1,400	40,000	0.03	0.06	1,000	40,000	0.02	0.05	720	30,000
	1.25	2.1	0.05	0.1	1,400	40,000	0.03	0.06	1,000	40,000	0.02	0.05	720	30,000
	1.5	2.5	0.05	0.1	1,400	40,000	0.03	0.06	1,000	40,000	0.02	0.05	720	30,000
	1.75	2.9	0.05	0.1	1,400	40,000	0.03	0.06	1,000	40,000	0.02	0.05	720	30,000
	2	3.3	0.05	0.1	1,400	40,000	0.03	0.06	1,000	40,000	0.02	0.05	720	30,000
	2.25	3.8	0.03	0.05	1,400	40,000	0.02	0.04	900	40,000	0.02	0.03	670	30,000
	2.5	4.2	0.03	0.05	1,200	40,000	0.02	0.04	840	40,000	0.02	0.03	640	30,000
	2.75	4.6	0.03	0.05	1,200	40,000	0.02	0.04	840	40,000	0.02	0.03	640	30,000
	3	5.0	0.03	0.05	1,200	40,000	0.02	0.04	840	40,000	0.02	0.03	640	30,000
	3.5	5.8	0.02	0.03	1,000	40,000	0.01	0.03	620	40,000	0.01	0.02	480	30,000
	4	6.7	0.02	0.03	1,000	40,000	0.01	0.03	620	40,000	0.01	0.02	480	30,000
	4.5	7.5	0.02	0.03	900	35,000	0.01	0.02	580	35,000	0.008	0.015	430	30,000
	5	8.3	0.01	0.02	720	30,000	0.007	0.015	500	30,000	0.007	0.01	400	30,000
	5.5	9.2	0.01	0.015	700	30,000	0.007	0.01	450	30,000	0.005	0.008	360	30,000
	6	10.0	0.007	0.01	500	30,000	0.005	0.007	380	30,000	0.004	0.006	320	30,000
	6.5	10.8	0.006	0.007	460	30,000	0.004	0.005	350	30,000	0.003	0.005	290	26,000
	7	11.7	0.005	0.007	400	25,000	0.003	0.005	300	25,000	0.003	0.003	260	20,000
7.5	12.5	0.004	0.006	360	25,000	0.003	0.004	280	25,000	0.002	0.003	240	20,000	
8	13.3	0.003	0.005	320	25,000	0.003	0.003	260	25,000	0.002	0.003	220	20,000	
9	15.0	0.003	0.003	280	25,000	0.003	0.002	220	25,000	0.001	0.002	160	20,000	
10	16.6	0.002	0.003	150	20,000	0.002	0.002	120	20,000	0.001	0.002	100	18,000	
12	20.0	0.002	0.002	80	20,000	0.002	0.002	60	20,000	0.001	0.002	50	18,000	

## Recommended Conditions (Metric)

Work Material			Hardened Steels SKD61·STAVAX·HPM-38 (~52HRC)				Hardened Steels SKD11 (~62HRC)				High Speed Steels SKH (~65HRC)			
Corner Radius	Under Neck Length	L/D	Depth of Cut		Feed	Spindle Speed	Depth of Cut		Feed	Spindle Speed	Depth of Cut		Feed	Spindle Speed
			a <sub>p</sub> mm	a <sub>e</sub> mm	mm/min	min <sup>-1</sup>	a <sub>p</sub> mm	a <sub>e</sub> mm	mm/min	min <sup>-1</sup>	a <sub>p</sub> mm	a <sub>e</sub> mm	mm/min	min <sup>-1</sup>
0.35	-	-	0.07	0.1	1,600	40,000	0.05	0.08	1,300	40,000	0.03	0.07	1,000	35,000
	1	1.4	0.07	0.1	1,600	40,000	0.05	0.08	1,300	40,000	0.03	0.07	1,000	35,000
	2	2.9	0.07	0.1	1,600	40,000	0.05	0.08	1,300	40,000	0.03	0.07	1,000	30,000
	4	5.7	0.04	0.06	1,300	40,000	0.03	0.04	820	40,000	0.015	0.02	600	30,000
	6	8.6	0.01	0.03	800	30,000	0.01	0.015	500	30,000	0.006	0.01	420	25,000
	8	11.4	0.006	0.01	520	25,000	0.005	0.006	380	20,000	0.004	0.006	250	20,000
0.4	-	-	0.1	0.15	2,000	40,000	0.08	0.12	1,600	40,000	0.06	0.1	1,200	35,000
	1	1.3	0.1	0.15	2,000	40,000	0.08	0.12	1,600	40,000	0.06	0.1	1,200	35,000
	1.5	1.9	0.1	0.15	2,000	40,000	0.08	0.12	1,600	40,000	0.06	0.1	1,200	35,000
	2	2.5	0.1	0.15	2,000	40,000	0.07	0.1	1,600	40,000	0.05	0.1	1,200	30,000
	2.5	3.1	0.1	0.15	2,000	40,000	0.07	0.1	1,600	40,000	0.05	0.08	1,200	30,000
	3	3.8	0.1	0.15	2,000	40,000	0.07	0.1	1,600	40,000	0.05	0.05	1,200	30,000
	3.5	4.4	0.08	0.12	2,000	40,000	0.06	0.08	1,600	40,000	0.04	0.05	1,200	30,000
	4	5.0	0.05	0.1	1,600	40,000	0.05	0.05	1,200	40,000	0.03	0.05	860	30,000
	4.5	5.6	0.05	0.08	1,600	40,000	0.04	0.05	1,200	40,000	0.02	0.04	860	30,000
	5	6.3	0.05	0.05	1,600	40,000	0.03	0.05	1,000	40,000	0.02	0.03	620	30,000
	6	7.5	0.03	0.05	1,200	30,000	0.02	0.03	760	30,000	0.01	0.02	560	25,000
	7	8.8	0.02	0.03	1,000	30,000	0.01	0.02	680	30,000	0.007	0.01	520	25,000
	8	10.0	0.01	0.02	820	30,000	0.007	0.01	600	30,000	0.005	0.01	480	25,000
	9	11.3	0.008	0.01	700	30,000	0.005	0.005	550	30,000	0.003	0.005	420	25,000
	10	12.5	0.005	0.005	450	25,000	0.003	0.003	380	25,000	0.002	0.003	320	20,000
	12	15.0	0.003	0.005	320	20,000	0.002	0.003	260	20,000	0.002	0.002	200	20,000
16	20.0	0.002	0.003	250	18,000	0.002	0.002	200	18,000	0.001	0.002	140	16,000	
0.45	-	-	0.1	0.2	2,200	40,000	0.08	0.15	1,800	32,000	0.06	0.1	1,300	30,000
	1	1.1	0.1	0.2	2,200	40,000	0.08	0.15	1,800	32,000	0.06	0.1	1,300	30,000
	2	2.2	0.1	0.2	2,200	40,000	0.08	0.15	1,800	30,000	0.06	0.1	1,300	30,000
	4	4.4	0.05	0.12	1,800	40,000	0.04	0.08	1,400	30,000	0.03	0.05	900	25,000
	6	6.7	0.035	0.05	1,200	30,000	0.025	0.035	800	25,000	0.015	0.025	600	20,000
	8	8.9	0.025	0.04	1,000	30,000	0.015	0.025	700	23,000	0.008	0.015	500	20,000
0.5	-	-	0.1	0.3	2,500	40,000	0.1	0.2	2,000	30,000	0.08	0.12	1,400	25,000
	1	1.0	0.1	0.3	2,500	40,000	0.1	0.2	2,000	30,000	0.08	0.12	1,400	25,000
	1.5	1.5	0.1	0.3	2,500	40,000	0.1	0.2	2,000	30,000	0.08	0.12	1,400	25,000
	2	2.0	0.1	0.3	2,500	40,000	0.1	0.2	2,000	30,000	0.08	0.1	1,400	25,000
	2.5	2.5	0.1	0.3	2,500	40,000	0.1	0.2	2,000	30,000	0.08	0.1	1,400	25,000
	3	3.0	0.1	0.3	2,500	40,000	0.1	0.2	2,000	30,000	0.08	0.1	1,400	25,000
	3.5	3.5	0.1	0.25	2,500	40,000	0.07	0.15	1,800	30,000	0.06	0.1	1,300	25,000
	4	4.0	0.1	0.2	2,500	40,000	0.05	0.15	1,800	30,000	0.05	0.1	1,200	25,000
	4.5	4.5	0.08	0.2	2,000	30,000	0.05	0.1	1,600	25,000	0.04	0.07	950	20,000
	5	5.0	0.05	0.15	2,000	30,000	0.04	0.1	1,600	25,000	0.03	0.05	920	20,000
	6	6.0	0.05	0.1	1,800	30,000	0.04	0.05	1,200	25,000	0.02	0.05	740	20,000
	7	7.0	0.04	0.06	1,200	30,000	0.03	0.04	950	25,000	0.02	0.03	680	20,000
	8	8.0	0.04	0.06	1,000	30,000	0.03	0.04	860	25,000	0.02	0.03	560	20,000
	9	9.0	0.03	0.05	820	25,000	0.02	0.03	750	20,000	0.01	0.02	500	18,000
	10	10.0	0.03	0.05	750	25,000	0.02	0.03	620	20,000	0.01	0.02	450	18,000
	12	12.0	0.01	0.03	600	20,000	0.007	0.02	520	18,000	0.005	0.01	400	16,000
	13	13.0	0.008	0.02	500	20,000	0.005	0.01	420	18,000	0.003	0.006	350	16,000
	14	14.0	0.005	0.01	420	20,000	0.003	0.007	360	18,000	0.002	0.005	320	16,000
	16	16.0	0.005	0.005	300	18,000	0.003	0.005	250	16,000	0.002	0.003	200	14,000
	18	18.0	0.003	0.005	180	18,000	0.002	0.005	120	16,000	0.002	0.002	85	14,000
	20	20.0	0.003	0.003	100	16,000	0.002	0.003	75	14,000	0.002	0.002	60	12,000
	22	22.0	0.002	0.003	50	14,000	0.002	0.002	40	12,000	0.001	0.002	35	10,000

## Recommended Conditions (Metric)

Work Material			Hardened Steels SKD61·STAVAX·HPM-38 (~52HRC)				Hardened Steels SKD11 (~62HRC)				High Speed Steels SKH (~65HRC)			
Corner Radius	Under Neck Length	L/D	Depth of Cut		Feed	Spindle Speed	Depth of Cut		Feed	Spindle Speed	Depth of Cut		Feed	Spindle Speed
			a <sub>p</sub> mm	a <sub>e</sub> mm	mm/min	min <sup>-1</sup>	a <sub>p</sub> mm	a <sub>e</sub> mm	mm/min	min <sup>-1</sup>	a <sub>p</sub> mm	a <sub>e</sub> mm	mm/min	min <sup>-1</sup>
0.6	1.2	1.0	0.1	0.3	2,500	30,000	0.1	0.2	2,000	30,000	0.05	0.1	1,600	25,000
	2.4	2.0	0.1	0.3	2,500	30,000	0.1	0.2	2,000	30,000	0.05	0.1	1,600	25,000
	4	3.3	0.1	0.2	2,500	30,000	0.07	0.2	2,000	30,000	0.05	0.1	1,600	25,000
	6	5.0	0.07	0.1	2,000	30,000	0.05	0.1	1,600	25,000	0.03	0.07	1,200	20,000
	8	6.7	0.05	0.1	1,600	30,000	0.03	0.07	1,200	25,000	0.02	0.05	920	20,000
0.6	10	8.3	0.03	0.07	1,200	20,000	0.02	0.05	860	20,000	0.01	0.03	680	18,000
	12	10.0	0.02	0.05	860	20,000	0.01	0.03	620	20,000	0.007	0.02	480	18,000
	14	11.7	0.02	0.03	600	18,000	0.01	0.02	400	18,000	0.005	0.01	300	16,000
	16	13.3	0.01	0.02	350	16,000	0.005	0.01	250	16,000	0.003	0.007	130	14,000
0.7	2	1.4	0.12	0.3	2,500	30,000	0.1	0.25	2,200	30,000	0.08	0.15	1,800	25,000
	4	2.9	0.12	0.25	2,500	30,000	0.1	0.2	2,200	30,000	0.05	0.15	1,800	25,000
	6	4.3	0.12	0.2	2,500	30,000	0.08	0.15	2,000	27,000	0.05	0.1	1,300	22,000
	8	5.7	0.12	0.2	2,500	30,000	0.08	0.15	1,800	20,000	0.03	0.08	1,000	20,000
	12	8.6	0.07	0.12	1,400	20,000	0.04	0.08	1,100	18,000	0.015	0.05	700	18,000
0.75	16	11.4	0.02	0.05	700	17,000	0.01	0.03	600	17,000	0.008	0.02	450	16,000
	2	1.3	0.15	0.3	3,000	30,000	0.1	0.3	2,500	30,000	0.1	0.2	2,000	25,000
	3	2.0	0.15	0.3	3,000	30,000	0.1	0.3	2,500	30,000	0.1	0.2	2,000	25,000
	4	2.7	0.15	0.3	3,000	30,000	0.1	0.3	2,500	30,000	0.1	0.2	2,000	25,000
	5	3.3	0.15	0.25	3,000	30,000	0.1	0.25	2,300	30,000	0.1	0.15	1,800	25,000
	6	4.0	0.15	0.2	3,000	30,000	0.1	0.2	2,000	30,000	0.1	0.1	1,600	25,000
	8	5.3	0.1	0.2	2,500	25,000	0.05	0.2	1,600	25,000	0.05	0.1	1,200	20,000
	10	6.7	0.1	0.1	2,500	25,000	0.05	0.1	1,200	25,000	0.05	0.05	860	20,000
	12	8.0	0.05	0.1	1,800	20,000	0.03	0.1	920	20,000	0.02	0.05	780	18,000
	14	9.3	0.05	0.07	1,200	20,000	0.03	0.05	820	20,000	0.02	0.03	650	18,000
	16	10.7	0.03	0.05	720	18,000	0.02	0.03	650	18,000	0.01	0.02	580	16,000
	18	12.0	0.02	0.04	550	16,000	0.012	0.025	400	16,000	0.008	0.015	400	14,000
	20	13.3	0.01	0.03	450	16,000	0.01	0.02	360	16,000	0.007	0.01	300	14,000
	22	14.7	0.01	0.02	330	14,000	0.01	0.01	250	14,000	0.007	0.007	200	12,000
25	16.7	0.008	0.01	180	12,000	0.005	0.005	140	12,000	0.004	0.004	110	10,000	
30	20.0	0.005	0.005	80	10,000	0.003	0.005	60	10,000	0.003	0.003	40	8,000	
0.8	2	1.3	0.15	0.3	3,000	30,000	0.1	0.25	2,500	25,000	0.1	0.2	2,000	20,000
	4	2.5	0.15	0.3	3,000	30,000	0.1	0.2	2,300	25,000	0.08	0.15	1,800	20,000
	6	3.8	0.15	0.25	3,000	30,000	0.1	0.2	2,000	23,000	0.07	0.12	1,600	20,000
	8	5.0	0.1	0.2	2,500	25,000	0.07	0.15	2,000	20,000	0.05	0.1	1,600	18,000
	12	7.5	0.07	0.1	1,800	20,000	0.05	0.07	1,500	16,000	0.03	0.05	1,200	14,000
	16	10.0	0.03	0.05	720	16,000	0.02	0.03	600	14,000	0.015	0.02	480	12,000
	20	12.5	0.01	0.03	500	14,000	0.01	0.02	380	12,000	0.01	0.01	300	10,000
0.9	3	1.7	0.15	0.35	3,000	27,000	0.12	0.3	2,500	25,000	0.1	0.25	2,000	20,000
	4	2.2	0.15	0.35	3,000	27,000	0.12	0.25	2,500	25,000	0.1	0.2	1,800	20,000
	6	3.3	0.15	0.35	3,000	27,000	0.12	0.25	2,500	25,000	0.1	0.2	1,600	18,000
	8	4.4	0.1	0.3	2,500	25,000	0.08	0.2	2,300	23,000	0.08	0.15	1,400	17,000
	10	5.6	0.1	0.3	2,000	20,000	0.08	0.2	1,700	18,000	0.08	0.12	1,100	14,000
	12	6.7	0.07	0.2	1,600	20,000	0.05	0.15	1,300	17,000	0.05	0.12	900	13,000
	16	8.9	0.07	0.15	1,200	18,000	0.05	0.1	1,000	16,000	0.03	0.1	720	12,000
	18	10.0	0.05	0.1	1,000	15,000	0.03	0.08	800	14,000	0.02	0.08	600	11,000
	20	11.1	0.05	0.08	800	15,000	0.03	0.05	640	13,000	0.02	0.05	430	9,000
	22	12.2	0.03	0.05	650	15,000	0.02	0.03	520	12,000	0.015	0.03	340	8,000
25	13.9	0.02	0.03	480	12,000	0.015	0.02	340	10,000	0.01	0.02	230	7,000	
30	16.7	0.01	0.02	300	12,000	0.007	0.01	210	10,000	0.005	0.01	120	6,000	



## Recommended Conditions (Metric)

Work Material			Hardened Steels SKD61·STAVAX·HPM-38 (~52HRC)				Hardened Steels SKD11 (~62HRC)				High Speed Steels SKH (~65HRC)			
Corner Radius	Under Neck Length	L/D	Depth of Cut		Feed	Spindle Speed	Depth of Cut		Feed	Spindle Speed	Depth of Cut		Feed	Spindle Speed
			a <sub>p</sub> mm	a <sub>e</sub> mm	mm/min	min <sup>-1</sup>	a <sub>p</sub> mm	a <sub>e</sub> mm	mm/min	min <sup>-1</sup>	a <sub>p</sub> mm	a <sub>e</sub> mm	mm/min	min <sup>-1</sup>
1	2	1.0	0.2	0.5	3,000	25,000	0.2	0.5	2,500	25,000	0.15	0.3	2,000	20,000
	3	1.5	0.2	0.5	3,000	25,000	0.2	0.5	2,500	25,000	0.15	0.3	2,000	20,000
	4	2.0	0.2	0.5	3,000	25,000	0.2	0.5	2,500	25,000	0.15	0.3	2,000	20,000
	6	3.0	0.2	0.4	2,500	25,000	0.2	0.3	2,000	25,000	0.15	0.3	1,600	20,000
	8	4.0	0.2	0.3	2,000	20,000	0.1	0.2	1,600	18,000	0.1	0.2	1,200	16,000
	10	5.0	0.1	0.3	2,000	18,000	0.1	0.2	1,600	16,000	0.1	0.1	1,200	14,000
	12	6.0	0.1	0.2	1,600	16,000	0.1	0.1	1,200	14,000	0.05	0.1	940	12,000
	13	6.5	0.08	0.2	1,600	16,000	0.06	0.1	1,200	14,000	0.04	0.08	940	12,000
	14	7.0	0.07	0.15	1,600	16,000	0.05	0.08	1,200	14,000	0.03	0.07	940	12,000
	16	8.0	0.07	0.15	1,600	16,000	0.05	0.08	1,200	14,000	0.03	0.07	940	12,000
	18	9.0	0.05	0.1	1,400	14,000	0.03	0.05	1,000	12,000	0.02	0.03	850	10,000
20	10.0	0.05	0.1	1,000	14,000	0.03	0.05	820	12,000	0.02	0.03	720	10,000	
1	22	11.0	0.03	0.08	850	14,000	0.02	0.06	700	12,000	0.02	0.02	600	10,000
	25	12.5	0.03	0.05	680	12,000	0.02	0.03	560	10,000	0.01	0.02	420	8,500
	27	13.5	0.02	0.05	500	12,000	0.015	0.03	410	10,000	0.01	0.02	330	8,500
	30	15.0	0.02	0.03	360	12,000	0.01	0.02	300	10,000	0.008	0.01	240	8,500
	32	16.0	0.02	0.02	230	10,000	0.01	0.015	180	8,000	0.008	0.01	150	6,800
	35	17.5	0.01	0.02	150	10,000	0.007	0.01	120	8,000	0.005	0.007	100	6,800
	40	20.0	0.005	0.01	100	10,000	0.003	0.005	80	8,000	0.002	0.003	50	6,800
1.25	4	1.6	0.3	0.5	3,000	20,000	0.2	0.5	2,500	20,000	0.15	0.4	2,000	18,000
	6	2.4	0.3	0.4	2,800	20,000	0.2	0.5	2,300	20,000	0.15	0.4	2,000	18,000
	8	3.2	0.25	0.3	2,600	20,000	0.15	0.3	2,100	20,000	0.12	0.25	1,800	18,000
	10	4.0	0.2	0.3	2,500	20,000	0.15	0.2	2,000	20,000	0.1	0.15	1,600	18,000
	15	6.0	0.1	0.2	2,000	18,000	0.07	0.15	1,600	16,000	0.05	0.1	1,200	14,000
	20	8.0	0.07	0.15	1,500	16,000	0.05	0.1	1,200	14,000	0.03	0.05	1,000	10,000
	25	10.0	0.05	0.1	1,000	14,000	0.03	0.07	850	12,000	0.02	0.03	720	8,000
	30	12.0	0.03	0.07	720	12,000	0.02	0.05	640	10,000	0.01	0.02	580	7,000
35	14.0	0.02	0.03	450	10,000	0.01	0.02	400	8,500	0.007	0.01	320	6,200	
1.5	6	2.0	0.2	0.8	3,000	20,000	0.2	0.6	2,500	18,000	0.2	0.5	2,000	14,000
	8	2.7	0.2	0.8	3,000	20,000	0.2	0.6	2,500	18,000	0.2	0.5	2,000	14,000
	10	3.3	0.2	0.6	2,500	20,000	0.2	0.4	2,000	18,000	0.1	0.3	1,500	14,000
	12	4.0	0.2	0.6	2,500	20,000	0.2	0.4	2,000	18,000	0.1	0.3	1,500	14,000
	14	4.7	0.1	0.4	2,000	18,000	0.1	0.3	1,600	16,000	0.1	0.2	1,200	12,000
	16	5.3	0.1	0.4	2,000	18,000	0.1	0.3	1,600	16,000	0.1	0.2	1,200	12,000
	18	6.0	0.1	0.3	1,800	18,000	0.1	0.2	1,400	16,000	0.1	0.15	1,100	12,000
	20	6.7	0.1	0.3	1,600	18,000	0.1	0.2	1,200	16,000	0.1	0.1	960	12,000
	22	7.3	0.1	0.2	1,400	17,000	0.07	0.15	1,000	15,000	0.07	0.07	880	11,000
	25	8.3	0.1	0.2	1,200	16,000	0.07	0.15	920	14,000	0.05	0.07	800	10,000
	27	9.0	0.07	0.1	1,000	14,000	0.05	0.08	800	12,000	0.03	0.05	700	9,000
	30	10.0	0.07	0.1	750	14,000	0.05	0.07	640	12,000	0.03	0.05	600	8,600
	35	11.7	0.05	0.1	620	12,000	0.03	0.07	500	10,000	0.02	0.05	420	7,200
40	13.3	0.03	0.07	450	10,000	0.02	0.05	320	8,200	0.01	0.03	260	6,400	
1.75	5	1.4	0.3	1	3,000	20,000	0.25	0.8	2,500	18,000	0.2	0.6	1,800	14,000
	10	2.9	0.25	1	3,000	20,000	0.2	0.6	2,500	18,000	0.15	0.5	1,700	14,000
	15	4.3	0.25	1	3,000	20,000	0.15	0.5	2,300	16,000	0.13	0.4	1,500	14,000
	20	5.7	0.18	0.6	2,500	18,000	0.1	0.3	1,800	15,000	0.1	0.2	1,200	12,000
	25	7.1	0.12	0.35	1,800	16,000	0.1	0.2	1,600	14,000	0.06	0.12	1,000	10,000
	30	8.6	0.1	0.25	1,500	14,000	0.07	0.15	950	11,000	0.05	0.08	800	9,000
	35	10.0	0.08	0.2	1,200	13,000	0.07	0.12	800	10,000	0.03	0.06	650	7,500
	40	11.4	0.07	0.1	800	11,000	0.04	0.07	720	9,000	0.02	0.05	450	7,000
	45	12.9	0.06	0.07	700	10,000	0.035	0.05	600	7,500	0.015	0.03	320	6,000

## Recommended Conditions (Metric)

Work Material			Hardened Steels SKD61·STAVAX·HPM-38 (~52HRC)				Hardened Steels SKD11 (~62HRC)				High Speed Steels SKH (~65HRC)			
Corner Radius	Under Neck Length	L/D	Depth of Cut		Feed	Spindle Speed	Depth of Cut		Feed	Spindle Speed	Depth of Cut		Feed	Spindle Speed
			a <sub>p</sub> mm	a <sub>e</sub> mm	mm/min	min <sup>-1</sup>	a <sub>p</sub> mm	a <sub>e</sub> mm	mm/min	min <sup>-1</sup>	a <sub>p</sub> mm	a <sub>e</sub> mm	mm/min	min <sup>-1</sup>
2	6	1.5	0.3	1.5	3,000	20,000	0.2	0.8	2,500	16,000	0.2	0.6	2,000	12,000
	8	2.0	0.3	1.5	3,000	20,000	0.2	0.8	2,500	16,000	0.2	0.6	2,000	12,000
	10	2.5	0.3	1.5	3,000	20,000	0.2	0.8	2,500	16,000	0.2	0.6	2,000	12,000
	12	3.0	0.3	1.5	3,000	20,000	0.2	0.8	2,500	16,000	0.2	0.6	2,000	12,000
	14	3.5	0.3	1.5	3,000	20,000	0.2	0.8	2,000	16,000	0.2	0.6	1,600	12,000
	15	3.8	0.3	1.5	3,000	20,000	0.2	0.8	2,000	16,000	0.2	0.6	1,600	12,000
	16	4.0	0.3	1	2,700	18,000	0.2	0.6	2,000	16,000	0.15	0.5	1,600	12,000
	18	4.5	0.2	1	2,700	18,000	0.15	0.6	1,800	14,000	0.12	0.4	1,400	10,000
	20	5.0	0.2	1	2,400	16,000	0.1	0.6	1,800	14,000	0.1	0.4	1,400	10,000
	22	5.5	0.2	0.8	2,000	16,000	0.1	0.5	1,500	14,000	0.1	0.3	1,200	10,000
	25	6.3	0.2	0.8	1,600	16,000	0.1	0.4	1,200	14,000	0.1	0.2	1,000	10,000
	27	6.8	0.15	0.5	1,600	16,000	0.1	0.3	1,200	14,000	0.07	0.2	1,000	10,000
	30	7.5	0.1	0.3	1,600	14,000	0.07	0.2	1,200	10,000	0.05	0.15	1,000	8,200
	35	8.8	0.1	0.2	1,200	14,000	0.07	0.15	1,000	10,000	0.05	0.1	820	8,200
	40	10.0	0.07	0.15	1,200	12,000	0.05	0.1	1,000	8,600	0.03	0.07	820	6,800
45	11.3	0.07	0.1	750	12,000	0.05	0.07	620	8,600	0.03	0.05	500	6,800	
50	12.5	0.05	0.08	550	10,000	0.03	0.05	500	7,500	0.02	0.03	420	5,500	
2.5	10	2.0	0.3	1.5	3,000	18,000	0.2	1.2	2,500	12,000	0.2	0.7	2,000	9,200
	15	3.0	0.3	1.5	3,000	18,000	0.2	1.2	2,500	12,000	0.2	0.7	2,000	9,200
	20	4.0	0.3	1.2	3,000	15,000	0.2	1	2,000	10,000	0.15	0.5	1,600	8,000
	25	5.0	0.2	1	2,500	15,000	0.15	0.8	1,800	8,600	0.1	0.3	1,200	7,200
	30	6.0	0.2	0.8	2,000	12,000	0.15	0.5	1,500	7,600	0.1	0.2	860	6,400
	35	7.0	0.15	0.5	1,500	10,000	0.1	0.3	1,100	7,300	0.07	0.15	750	6,000
	40	8.0	0.1	0.2	1,200	10,000	0.07	0.15	1,000	6,800	0.05	0.1	650	5,500
	45	9.0	0.1	0.15	1,000	10,000	0.07	0.1	760	6,400	0.05	0.07	550	4,800
50	10.0	0.08	0.1	800	9,000	0.05	0.07	530	6,000	0.03	0.05	360	4,000	
3	8	1.3	0.3	2	3,000	16,000	0.3	1.2	2,500	8,000	0.2	1	2,000	7,000
	10	1.7	0.3	2	3,000	16,000	0.3	1.2	2,500	8,000	0.2	1	2,000	7,000
	12	2.0	0.3	2	3,000	16,000	0.3	1.2	2,500	8,000	0.2	1	2,000	7,000
	15	2.5	0.3	2	3,000	16,000	0.3	1.2	2,500	8,000	0.2	1	2,000	7,000
	18	3.0	0.3	2	3,000	16,000	0.3	1.2	2,500	8,000	0.2	1	2,000	7,000
	20	3.3	0.3	2	3,000	16,000	0.3	1.2	2,500	8,000	0.2	1	2,000	7,000
	25	4.2	0.3	1.5	3,000	16,000	0.2	1	2,000	8,000	0.15	0.7	1,500	7,000
	30	5.0	0.2	1.5	3,000	14,000	0.2	1	2,000	7,200	0.15	0.7	1,500	6,500
	35	5.8	0.2	1.2	2,400	13,000	0.17	0.8	1,600	6,800	0.12	0.5	1,200	5,800
	40	6.7	0.2	1	1,800	12,000	0.15	0.6	1,200	6,400	0.1	0.4	1,000	5,200
	50	8.3	0.1	0.6	1,200	8,200	0.1	0.3	860	4,800	0.05	0.2	620	4,000
60	10.0	0.07	0.3	600	6,000	0.05	0.15	450	3,200	0.03	0.07	300	2,500	

## Notes

※ Recommended RPM based upon ideal conditions.

RPM may be adjusted to match the capabilities of your machine while maintaining constant feed rate per cutting tooth.

※1 Depth of Cut : a<sub>p</sub> = Axial Depth of Cut / a<sub>e</sub> = Radial Depth of Cut.

※2 We recommend using oil mist coolant.

※3 Adjust both spindle speed and feed at the same rate.

※4 Adjust milling conditions according to the volume of depth of cut and rigidity of machine.

※5 Length of tool overhang must be as short as possible.

## Recommended Conditions (Inch)

Work Material			Hardened Steels SKD61・STAVAX・HPM-38 (~52HRC)					Hardened Steels SKD11 (~62HRC)					High Speed Steels SKH (~65HRC)				
Corner Radius	Under Neck Length	L/D	Depth of Cut		Feed per tooth	Feed	Spindle Speed	Depth of Cut		Feed per tooth	Feed	Spindle Speed	Depth of Cut		Feed per tooth	Feed	Spindle Speed
			ap Inch	ae Inch	IPT fz	IPM	RPM	ap Inch	ae Inch	IPT fz	IPM	RPM	ap Inch	ae Inch	IPT fz	IPM	RPM
0.05	0.2	2.0	.00012	.00020	.00006	3.94	40,000	.00008	.00020	.00005	3.94	40,000	.00008	.00012	.00003	2.76	40,000
	0.25	2.5	.00012	.00020	.00005	4.33	40,000	.00008	.00020	.00004	3.15	40,000	.00008	.00012	.00002	1.97	40,000
	0.3	3.0	.00012	.00020	.00005	3.94	40,000	.00008	.00020	.00003	2.76	40,000	.00008	.00012	.00002	1.97	40,000
	0.35	3.5	.00008	.00020	.00005	3.94	40,000	.00004	.00020	.00003	2.76	40,000	.00004	.00012	.00002	1.97	40,000
	0.4	4.0	.00008	.00020	.00004	3.54	40,000	.00004	.00020	.00003	2.76	40,000	.00004	.00012	.00002	1.97	40,000
	0.45	4.5	.00008	.00012	.00004	3.15	40,000	.00004	.00012	.00003	2.36	40,000	.00004	.00008	.00002	1.57	40,000
	0.5	5.0	.00008	.00012	.00003	2.76	40,000	.00004	.00012	.00002	1.97	40,000	.00004	.00008	.00001	1.18	40,000
0.075	0.25	1.7	.00012	.00020	.00010	7.87	40,000	.00008	.00020	.00008	6.3	40,000	.00008	.00012	.00006	4.72	40,000
	0.3	2.0	.00012	.00020	.00009	7.09	40,000	.00008	.00020	.00007	5.91	40,000	.00008	.00012	.00005	3.94	40,000
	0.35	2.3	.00012	.00020	.00009	7.09	40,000	.00008	.00020	.00007	5.91	40,000	.00008	.00012	.00005	3.94	40,000
	0.4	2.6	.00012	.00020	.00007	5.91	40,000	.00008	.00020	.00006	4.72	40,000	.00008	.00012	.00003	2.76	40,000
	0.45	3.0	.00012	.00020	.00007	5.91	40,000	.00008	.00020	.00006	4.72	40,000	.00008	.00012	.00003	2.76	40,000
	0.5	3.3	.00012	.00020	.00007	5.91	40,000	.00008	.00020	.00006	4.72	40,000	.00008	.00012	.00003	2.76	40,000
	0.6	4.0	.00008	.00012	.00006	4.72	40,000	.00004	.00012	.00005	3.94	40,000	.00004	.00008	.00002	1.97	40,000
0.1	0.75	5.0	.00008	.00012	.00005	3.94	40,000	.00004	.00012	.00004	3.15	40,000	.00004	.00008	.00002	1.57	40,000
	1	6.7	.00008	.00012	.00003	2.76	40,000	.00004	.00012	.00002	1.97	40,000	.00004	.00008	.00001	1.18	40,000
	0.3	1.5	.00039	.00039	.00017	13.78	40,000	.00024	.00020	.00015	11.81	40,000	.00012	.00012	.00010	7.87	40,000
	0.4	2.0	.00031	.00039	.00016	12.99	40,000	.00020	.00020	.00014	11.42	40,000	.00012	.00012	.00010	7.87	40,000
	0.5	2.5	.00031	.00039	.00016	12.6	40,000	.00020	.00020	.00014	11.02	40,000	.00012	.00012	.00009	7.09	40,000
	0.6	3.0	.00020	.00039	.00015	11.81	40,000	.00012	.00020	.00012	9.84	40,000	.00008	.00012	.00008	6.3	40,000
	0.75	3.8	.00020	.00039	.00014	11.02	40,000	.00012	.00020	.00010	7.87	40,000	.00008	.00012	.00007	5.91	40,000
	0.85	4.3	.00012	.00020	.00013	10.24	40,000	.00008	.00020	.00009	7.09	40,000	.00004	.00012	.00006	5.12	40,000
	1	5.0	.00012	.00020	.00012	9.84	40,000	.00008	.00012	.00008	6.3	40,000	.00004	.00008	.00006	4.72	40,000
	1.25	6.3	.00012	.00020	.00009	7.09	40,000	.00008	.00012	.00007	5.51	40,000	.00004	.00008	.00005	3.94	40,000
	1.5	7.5	.00012	.00020	.00007	5.91	40,000	.00008	.00012	.00006	4.72	40,000	.00004	.00008	.00004	3.15	40,000
	1.75	8.8	.00008	.00012	.00006	4.72	40,000	.00004	.00008	.00005	3.94	40,000	.00004	.00008	.00003	2.36	40,000
	2	10.0	.00008	.00012	.00005	3.94	40,000	.00004	.00008	.00004	3.15	40,000	.00004	.00004	.00002	1.97	40,000
	2.25	11.3	.00004	.00008	.00004	3.15	40,000	.00004	.00004	.00003	2.76	40,000	.00004	.00004	.00002	1.77	40,000
	2.5	12.5	.00004	.00008	.00003	2.76	40,000	.00004	.00004	.00003	2.36	40,000	.00004	.00004	.00002	1.57	40,000
2.75	13.8	.00004	.00004	.00003	2.36	40,000	.00004	.00004	.00002	1.97	40,000	.00004	.00004	.00002	1.38	40,000	
3	15.0	.00004	.00004	.00002	1.97	40,000	.00004	.00004	.00002	1.57	40,000	.00004	.00004	.00001	1.18	40,000	
0.15	-	-	.00039	.00059	.00022	17.72	40,000	.00028	.00039	.00019	14.96	40,000	.00012	.00020	.00016	12.6	40,000
	0.5	1.6	.00039	.00059	.00017	13.78	40,000	.00028	.00039	.00015	11.81	40,000	.00012	.00020	.00014	11.02	40,000
	0.6	2.0	.00028	.00039	.00017	13.78	40,000	.00020	.00028	.00015	11.81	40,000	.00012	.00020	.00012	9.84	40,000
	0.75	2.5	.00028	.00039	.00016	12.99	40,000	.00020	.00028	.00014	11.02	40,000	.00012	.00020	.00011	9.06	40,000
	1	3.3	.00028	.00039	.00016	12.6	40,000	.00020	.00028	.00012	9.84	40,000	.00012	.00020	.00010	7.87	40,000
	1.25	4.2	.00020	.00028	.00014	11.02	40,000	.00012	.00020	.00010	7.87	40,000	.00008	.00012	.00008	6.3	40,000
	1.5	5.0	.00020	.00028	.00011	9.06	40,000	.00012	.00020	.00009	7.09	40,000	.00008	.00012	.00006	4.72	40,000
	1.75	5.8	.00012	.00020	.00009	7.09	40,000	.00008	.00012	.00007	5.91	40,000	.00008	.00008	.00005	3.94	40,000
	2	6.6	.00012	.00020	.00007	5.91	40,000	.00008	.00012	.00006	4.72	40,000	.00008	.00008	.00004	3.54	40,000
	2.25	7.5	.00008	.00012	.00006	4.72	40,000	.00004	.00008	.00005	3.94	40,000	.00004	.00004	.00004	3.15	40,000
	2.5	8.3	.00008	.00012	.00005	3.94	40,000	.00004	.00008	.00004	3.15	40,000	.00004	.00004	.00003	2.76	40,000
	3	10.0	.00004	.00012	.00004	3.15	40,000	.00004	.00008	.00003	2.76	40,000	.00004	.00004	.00003	2.36	40,000
	3.5	11.7	.00004	.00008	.00003	2.76	40,000	.00004	.00004	.00003	2.36	40,000	.00004	.00004	.00002	1.97	40,000
	4	13.3	.00004	.00008	.00003	2.36	40,000	.00004	.00004	.00002	1.97	40,000	.00004	.00004	.00002	1.57	40,000
	4.5	15.0	.00004	.00004	.00002	1.97	40,000	.00004	.00004	.00002	1.57	40,000	.00004	.00004	.00001	1.18	40,000
0.2	-	-	.00118	.00197	.00039	31.5	40,000	.00118	.00118	.00035	28.35	40,000	.00035	.00079	.00029	22.83	40,000
	0.5	1.3	.00118	.00197	.00039	31.5	40,000	.00118	.00118	.00035	28.35	40,000	.00035	.00079	.00029	22.83	40,000
	0.65	1.6	.00098	.00197	.00039	31.5	40,000	.00098	.00118	.00035	28.35	40,000	.00035	.00079	.00029	22.83	40,000
	0.8	2.0	.00079	.00197	.00039	31.5	40,000	.00079	.00118	.00035	28.35	40,000	.00031	.00079	.00029	22.83	40,000
	1	2.5	.00079	.00197	.00039	31.5	40,000	.00079	.00118	.00035	28.35	40,000	.00031	.00079	.00029	22.83	40,000
	1.25	3.1	.00059	.00157	.00034	27.56	40,000	.00059	.00079	.00031	24.41	40,000	.00024	.00079	.00023	18.5	40,000
	1.5	3.8	.00039	.00118	.00031	24.41	40,000	.00039	.00079	.00025	19.69	40,000	.00020	.00039	.00020	15.75	40,000
	1.75	4.4	.00039	.00098	.00029	22.83	40,000	.00039	.00079	.00022	17.72	40,000	.00020	.00039	.00017	13.39	40,000
	2	5.0	.00039	.00079	.00025	19.69	40,000	.00039	.00039	.00019	14.96	40,000	.00020	.00028	.00015	11.81	40,000
2.25	5.6	.00039	.00059	.00023	18.11	40,000	.00020	.00039	.00016	12.99	40,000	.00012	.00020	.00014	11.02	40,000	

## Recommended Conditions (Inch)

Work Material			Hardened Steels SKD61・STAVAX・HPM-38 (~52HRC)					Hardened Steels SKD11 (~62HRC)					High Speed Steels SKH (~65HRC)				
Corner Radius	Under Neck Length	L/D	Depth of Cut		Feed per tooth	Feed	Spindle Speed	Depth of Cut		Feed per tooth	Feed	Spindle Speed	Depth of Cut		Feed per tooth	Feed	Spindle Speed
			ap Inch	ae Inch	IPT fz	IPM	RPM	ap Inch	ae Inch	IPT fz	IPM	RPM	ap Inch	ae Inch	IPT fz	IPM	RPM
0.2	2.5	6.3	.00028	.00039	.00021	16.54	40,000	.00020	.00028	.00015	11.81	40,000	.00012	.00020	.00013	10.24	40,000
	2.75	6.9	.00028	.00039	.00017	13.78	40,000	.00020	.00028	.00014	11.02	40,000	.00012	.00020	.00011	8.66	40,000
	3	7.5	.00028	.00039	.00015	11.81	40,000	.00020	.00028	.00012	9.45	40,000	.00012	.00020	.00010	7.87	40,000
	3.5	8.8	.00020	.00028	.00011	9.06	40,000	.00012	.00020	.00008	6.3	40,000	.00008	.00012	.00006	4.72	40,000
	4	10.0	.00020	.00020	.00011	6.3	30,000	.00012	.00012	.00008	4.72	30,000	.00008	.00012	.00006	3.54	30,000
	4.5	11.3	.00012	.00020	.00007	3.94	30,000	.00008	.00012	.00005	3.15	30,000	.00004	.00008	.00004	2.36	30,000
	5	12.5	.00008	.00012	.00005	2.76	30,000	.00004	.00008	.00003	1.97	30,000	.00004	.00008	.00003	1.57	30,000
	5.5	13.8	.00004	.00008	.00004	2.36	30,000	.00004	.00008	.00003	1.57	30,000	.00004	.00004	.00003	1.57	30,000
6	15.0	.00004	.00008	.00003	1.97	30,000	.00004	.00004	.00003	1.57	30,000	.00004	.00004	.00002	1.18	30,000	
-	-	.00157	.00276	.00049	39.37	40,000	.00118	.00197	.00042	33.86	40,000	.00059	.00118	.00032	25.59	40,000	
0.5	1.0	.00157	.00276	.00049	39.37	40,000	.00118	.00157	.00042	33.86	40,000	.00059	.00118	.00032	25.59	40,000	
0.75	1.5	.00118	.00236	.00049	39.37	40,000	.00098	.00118	.00042	33.86	40,000	.00047	.00079	.00032	25.59	40,000	
1	2.0	.00118	.00197	.00049	39.37	40,000	.00079	.00118	.00042	33.86	40,000	.00039	.00079	.00032	25.59	40,000	
1.25	2.5	.00098	.00197	.00045	36.22	40,000	.00079	.00118	.00038	30.71	40,000	.00039	.00079	.00029	22.83	40,000	
1.5	3.0	.00079	.00197	.00042	33.46	40,000	.00039	.00118	.00035	28.35	40,000	.00028	.00079	.00026	20.47	40,000	
1.75	3.5	.00079	.00157	.00039	31.5	40,000	.00039	.00118	.00033	26.77	40,000	.00028	.00079	.00024	18.9	40,000	
2	4.0	.00079	.00118	.00035	28.35	40,000	.00039	.00079	.00032	25.59	40,000	.00028	.00039	.00020	15.75	40,000	
2.25	4.5	.00059	.00118	.00032	25.59	40,000	.00028	.00079	.00029	22.83	40,000	.00020	.00039	.00019	14.96	40,000	
2.5	5.0	.00039	.00079	.00030	23.62	40,000	.00028	.00039	.00026	20.87	40,000	.00020	.00028	.00018	14.17	40,000	
3	6.0	.00039	.00079	.00025	19.69	40,000	.00028	.00039	.00021	16.54	40,000	.00020	.00028	.00016	12.6	40,000	
3.5	7.0	.00028	.00039	.00021	16.54	40,000	.00020	.00028	.00018	14.17	40,000	.00012	.00020	.00014	11.02	40,000	
4	8.0	.00028	.00039	.00017	13.78	40,000	.00020	.00028	.00015	11.81	40,000	.00012	.00020	.00013	10.24	40,000	
4.5	9.0	.00020	.00020	.00015	11.81	40,000	.00012	.00012	.00013	10.24	40,000	.00008	.00012	.00011	8.66	40,000	
5	10.0	.00020	.00020	.00014	9.45	33,000	.00012	.00012	.00012	7.87	33,000	.00008	.00012	.00011	7.09	33,000	
5.5	11.0	.00012	.00020	.00013	7.87	30,000	.00008	.00012	.00011	6.3	30,000	.00004	.00008	.00008	4.72	30,000	
6	12.0	.00008	.00012	.00008	4.72	30,000	.00004	.00008	.00005	3.15	30,000	.00004	.00008	.00005	2.76	30,000	
7	14.0	.00008	.00008	.00006	3.54	30,000	.00004	.00008	.00005	2.76	30,000	.00004	.00008	.00004	2.36	30,000	
8	16.0	.00008	.00008	.00005	2.95	30,000	.00004	.00008	.00004	2.36	30,000	.00004	.00008	.00003	1.97	30,000	
9	18.0	.00004	.00008	.00005	2.36	25,000	.00004	.00008	.00004	1.97	25,000	.00004	.00004	.00003	1.38	22,000	
10	20.0	.00004	.00008	.00004	1.57	20,000	.00004	.00008	.00003	1.18	20,000	.00004	.00004	.00002	0.79	20,000	
-	-	.00197	.00394	.00069	55.12	40,000	.00118	.00315	.00049	39.37	40,000	.00079	.00197	.00041	28.35	35,000	
0.6	1.0	.00197	.00394	.00069	55.12	40,000	.00118	.00315	.00049	39.37	40,000	.00079	.00197	.00041	28.35	35,000	
0.8	1.3	.00197	.00394	.00069	55.12	40,000	.00118	.00315	.00049	39.37	40,000	.00079	.00197	.00041	28.35	35,000	
1	1.7	.00197	.00394	.00069	55.12	40,000	.00118	.00236	.00049	39.37	40,000	.00079	.00197	.00047	28.35	30,000	
1.25	2.1	.00197	.00394	.00069	55.12	40,000	.00118	.00236	.00049	39.37	40,000	.00079	.00197	.00047	28.35	30,000	
1.5	2.5	.00197	.00394	.00069	55.12	40,000	.00118	.00236	.00049	39.37	40,000	.00079	.00197	.00047	28.35	30,000	
1.75	2.9	.00197	.00394	.00069	55.12	40,000	.00118	.00236	.00049	39.37	40,000	.00079	.00197	.00047	28.35	30,000	
2	3.3	.00197	.00394	.00069	55.12	40,000	.00118	.00236	.00049	39.37	40,000	.00079	.00197	.00047	28.35	30,000	
2.25	3.8	.00118	.00197	.00069	55.12	40,000	.00079	.00157	.00044	35.43	40,000	.00079	.00118	.00044	26.38	30,000	
2.5	4.2	.00118	.00197	.00059	47.24	40,000	.00079	.00157	.00041	33.07	40,000	.00079	.00118	.00042	25.2	30,000	
2.75	4.6	.00118	.00197	.00059	47.24	40,000	.00079	.00157	.00041	33.07	40,000	.00079	.00118	.00042	25.2	30,000	
3	5.0	.00118	.00197	.00059	47.24	40,000	.00079	.00157	.00041	33.07	40,000	.00079	.00118	.00042	25.2	30,000	
3.5	5.8	.00079	.00118	.00049	39.37	40,000	.00039	.00118	.00031	24.41	40,000	.00039	.00079	.00032	18.9	30,000	
4	6.7	.00079	.00118	.00049	39.37	40,000	.00039	.00118	.00031	24.41	40,000	.00039	.00079	.00032	18.9	30,000	
4.5	7.5	.00079	.00118	.00051	35.43	35,000	.00039	.00079	.00033	22.83	35,000	.00031	.00059	.00028	16.93	30,000	
5	8.3	.00039	.00079	.00047	28.35	30,000	.00028	.00059	.00033	19.69	30,000	.00028	.00039	.00026	15.75	30,000	
5.5	9.2	.00039	.00059	.00046	27.56	30,000	.00028	.00039	.00030	17.72	30,000	.00020	.00031	.00024	14.17	30,000	
6	10.0	.00028	.00039	.00033	19.69	30,000	.00020	.00028	.00025	14.96	30,000	.00016	.00024	.00021	12.6	30,000	
6.5	10.8	.00024	.00028	.00030	18.11	30,000	.00016	.00020	.00023	13.78	30,000	.00012	.00020	.00022	11.42	26,000	
7	11.7	.00020	.00028	.00032	15.75	25,000	.00012	.00020	.00024	11.81	25,000	.00012	.00012	.00026	10.24	20,000	
7.5	12.5	.00016	.00024	.00028	14.17	25,000	.00012	.00016	.00022	11.02	25,000	.00008	.00012	.00024	9.45	20,000	
8	13.3	.00012	.00020	.00025	12.6	25,000	.00012	.00012	.00020	10.24	25,000	.00008	.00012	.00022	8.66	20,000	
9	15.0	.00012	.00012	.00022	11.02	25,000	.00012	.00008	.00017	8.66	25,000	.00004	.00008	.00016	6.3	20,000	
10	16.6	.00008	.00012	.00015	5.91	20,000	.00008	.00008	.00012	4.72	20,000	.00004	.00008	.00011	3.94	18,000	
12	20.0	.00008	.00008	.00008	3.15	20,000	.00008	.00008	.00006	2.36	20,000	.00004	.00008	.00005	1.97	18,000	

## Recommended Conditions (Inch)

Work Material			Hardened Steels SKD61・STAVAX・HPM-38 (～52HRC)					Hardened Steels SKD11 (～62HRC)					High Speed Steels SKH (～65HRC)				
Corner Radius	Under Neck Length	L/D	Depth of Cut		Feed per tooth	Feed	Spindle Speed	Depth of Cut		Feed per tooth	Feed	Spindle Speed	Depth of Cut		Feed per tooth	Feed	Spindle Speed
			ap Inch	ae Inch	IPT fz	IPM	RPM	ap Inch	ae Inch	IPT fz	IPM	RPM	ap Inch	ae Inch	IPT fz	IPM	RPM
0.35	-	-	.00276	.00394	.00079	62.99	40,000	.00197	.00315	.00064	51.18	40,000	.00118	.00276	.00056	39.37	35,000
	1	1.4	.00276	.00394	.00079	62.99	40,000	.00197	.00315	.00064	51.18	40,000	.00118	.00276	.00056	39.37	35,000
	2	2.9	.00276	.00394	.00079	62.99	40,000	.00197	.00315	.00064	51.18	40,000	.00118	.00276	.00066	39.37	30,000
	4	5.7	.00157	.00236	.00064	51.18	40,000	.00118	.00157	.00040	32.28	40,000	.00059	.00079	.00039	23.62	30,000
	6	8.6	.00039	.00118	.00053	31.5	30,000	.00039	.00059	.00033	19.69	30,000	.00024	.00039	.00033	16.54	25,000
	8	11.4	.00024	.00039	.00041	20.47	25,000	.00020	.00024	.00037	14.96	20,000	.00016	.00024	.00025	9.84	20,000
0.4	-	-	.00394	.00591	.00098	78.74	40,000	.00315	.00472	.00079	62.99	40,000	.00236	.00394	.00067	47.24	35,000
	1	1.3	.00394	.00591	.00098	78.74	40,000	.00315	.00472	.00079	62.99	40,000	.00236	.00394	.00067	47.24	35,000
	1.5	1.9	.00394	.00591	.00098	78.74	40,000	.00315	.00472	.00079	62.99	40,000	.00236	.00394	.00067	47.24	35,000
	2	2.5	.00394	.00591	.00098	78.74	40,000	.00276	.00394	.00079	62.99	40,000	.00197	.00394	.00079	47.24	30,000
	2.5	3.1	.00394	.00591	.00098	78.74	40,000	.00276	.00394	.00079	62.99	40,000	.00197	.00315	.00079	47.24	30,000
	3	3.8	.00394	.00591	.00098	78.74	40,000	.00276	.00394	.00079	62.99	40,000	.00197	.00315	.00079	47.24	30,000
	3.5	4.4	.00315	.00472	.00098	78.74	40,000	.00236	.00315	.00079	62.99	40,000	.00157	.00197	.00079	47.24	30,000
	4	5.0	.00197	.00394	.00079	62.99	40,000	.00197	.00197	.00059	47.24	40,000	.00118	.00197	.00056	33.86	30,000
	4.5	5.6	.00197	.00315	.00079	62.99	40,000	.00157	.00197	.00059	47.24	40,000	.00079	.00157	.00056	33.86	30,000
	5	6.3	.00197	.00197	.00079	62.99	40,000	.00118	.00197	.00049	39.37	40,000	.00079	.00118	.00041	24.41	30,000
	6	7.5	.00118	.00197	.00079	47.24	30,000	.00079	.00118	.00050	29.92	30,000	.00039	.00079	.00044	22.05	25,000
	7	8.8	.00079	.00118	.00066	39.37	30,000	.00039	.00079	.00045	26.77	30,000	.00028	.00039	.00041	20.47	25,000
	8	10.0	.00039	.00079	.00054	32.28	30,000	.00028	.00039	.00039	23.62	30,000	.00020	.00039	.00038	18.9	25,000
	9	11.3	.00031	.00039	.00046	27.56	30,000	.00020	.00020	.00036	21.65	30,000	.00012	.00020	.00033	16.54	25,000
	10	12.5	.00020	.00020	.00035	17.72	25,000	.00012	.00012	.00030	14.96	25,000	.00008	.00012	.00032	12.6	20,000
	12	15.0	.00012	.00020	.00032	12.6	20,000	.00008	.00012	.00026	10.24	20,000	.00008	.00008	.00020	7.87	20,000
16	20.0	.00008	.00012	.00027	9.84	18,000	.00008	.00008	.00022	7.87	18,000	.00004	.00008	.00017	5.51	16,000	
0.45	-	-	.00394	.00787	.00108	86.61	40,000	.00315	.00591	.00111	70.87	32,000	.00236	.00394	.00085	51.18	30,000
	1	1.1	.00394	.00787	.00108	86.61	40,000	.00315	.00591	.00111	70.87	32,000	.00236	.00394	.00085	51.18	30,000
	2	2.2	.00394	.00787	.00108	86.61	40,000	.00315	.00591	.00111	70.87	30,000	.00236	.00394	.00085	51.18	30,000
	4	4.4	.00197	.00472	.00089	70.87	40,000	.00157	.00315	.00092	55.12	30,000	.00118	.00197	.00071	35.43	25,000
	6	6.7	.00138	.00197	.00079	47.24	30,000	.00098	.00138	.00063	31.5	25,000	.00059	.00098	.00059	23.62	20,000
	8	8.9	.00098	.00157	.00066	39.37	30,000	.00059	.00098	.00060	27.56	23,000	.00031	.00059	.00049	19.69	20,000
0.5	-	-	.00394	.01181	.00123	98.43	40,000	.00394	.00787	.00131	78.74	30,000	.00315	.00472	.00110	55.12	25,000
	1	1.0	.00394	.01181	.00123	98.43	40,000	.00394	.00787	.00131	78.74	30,000	.00315	.00472	.00110	55.12	25,000
	1.5	1.5	.00394	.01181	.00123	98.43	40,000	.00394	.00787	.00131	78.74	30,000	.00315	.00472	.00110	55.12	25,000
	2	2.0	.00394	.01181	.00123	98.43	40,000	.00394	.00787	.00131	78.74	30,000	.00315	.00394	.00110	55.12	25,000
	2.5	2.5	.00394	.01181	.00123	98.43	40,000	.00394	.00787	.00131	78.74	30,000	.00315	.00394	.00110	55.12	25,000
	3	3.0	.00394	.01181	.00123	98.43	40,000	.00394	.00787	.00131	78.74	30,000	.00315	.00394	.00110	55.12	25,000
	3.5	3.5	.00394	.00984	.00123	98.43	40,000	.00276	.00591	.00118	70.87	30,000	.00236	.00394	.00102	51.18	25,000
	4	4.0	.00394	.00787	.00123	98.43	40,000	.00197	.00591	.00118	70.87	30,000	.00197	.00394	.00094	47.24	25,000
	4.5	4.5	.00315	.00787	.00131	78.74	30,000	.00197	.00394	.00126	62.99	25,000	.00157	.00276	.00094	37.4	20,000
	5	5.0	.00197	.00591	.00131	78.74	30,000	.00157	.00394	.00126	62.99	25,000	.00118	.00197	.00091	36.22	20,000
	6	6.0	.00197	.00394	.00118	70.87	30,000	.00157	.00197	.00094	47.24	25,000	.00079	.00197	.00073	29.13	20,000
	7	7.0	.00157	.00236	.00079	47.24	30,000	.00118	.00157	.00075	37.4	25,000	.00079	.00118	.00067	26.77	20,000
	8	8.0	.00157	.00236	.00066	39.37	30,000	.00118	.00157	.00068	33.86	25,000	.00079	.00118	.00055	22.05	20,000
	9	9.0	.00118	.00197	.00065	32.28	25,000	.00079	.00118	.00074	29.53	20,000	.00039	.00079	.00055	19.69	18,000
	10	10.0	.00118	.00197	.00059	29.53	25,000	.00079	.00118	.00061	24.41	20,000	.00039	.00079	.00049	17.72	18,000
	12	12.0	.00039	.00118	.00059	23.62	20,000	.00028	.00079	.00057	20.47	18,000	.00020	.00039	.00049	15.75	16,000
	13	13.0	.00031	.00079	.00049	19.69	20,000	.00020	.00039	.00046	16.54	18,000	.00012	.00024	.00043	13.78	16,000
	14	14.0	.00020	.00039	.00041	16.54	20,000	.00012	.00028	.00039	14.17	18,000	.00008	.00020	.00039	12.6	16,000
	16	16.0	.00020	.00020	.00033	11.81	18,000	.00012	.00020	.00031	9.84	16,000	.00008	.00012	.00028	7.87	14,000
	18	18.0	.00012	.00020	.00020	7.09	18,000	.00008	.00020	.00015	4.72	16,000	.00008	.00008	.00012	3.35	14,000
	20	20.0	.00012	.00012	.00012	3.94	16,000	.00008	.00012	.00011	2.95	14,000	.00008	.00008	.00010	2.36	12,000
	22	22.0	.00008	.00012	.00007	1.97	14,000	.00008	.00008	.00007	1.57	12,000	.00004	.00008	.00007	1.38	10,000



## Recommended Conditions (Inch)

Work Material			Hardened Steels SKD61・STAVAX・HPM-38 (~52HRC)					Hardened Steels SKD11 (~62HRC)					High Speed Steels SKH (~65HRC)				
Corner Radius	Under Neck Length	L/D	Depth of Cut		Feed per tooth	Feed	Spindle Speed	Depth of Cut		Feed per tooth	Feed	Spindle Speed	Depth of Cut		Feed per tooth	Feed	Spindle Speed
			ap Inch	ae Inch	IPT fz	IPM	RPM	ap Inch	ae Inch	IPT fz	IPM	RPM	ap Inch	ae Inch	IPT fz	IPM	RPM
0.6	1.2	1.0	.00394	.01181	.00164	98.43	30,000	.00394	.00787	.00131	78.74	30,000	.00197	.00394	.00126	62.99	25,000
	2.4	2.0	.00394	.01181	.00164	98.43	30,000	.00394	.00787	.00131	78.74	30,000	.00197	.00394	.00126	62.99	25,000
	4	3.3	.00394	.00787	.00164	98.43	30,000	.00276	.00787	.00131	78.74	30,000	.00197	.00394	.00126	62.99	25,000
	6	5.0	.00276	.00394	.00131	78.74	30,000	.00197	.00394	.00126	62.99	25,000	.00118	.00276	.00118	47.24	20,000
	8	6.7	.00197	.00394	.00105	62.99	30,000	.00118	.00276	.00094	47.24	25,000	.00079	.00197	.00091	36.22	20,000
0.6	10	8.3	.00118	.00276	.00118	47.24	20,000	.00079	.00197	.00085	33.86	20,000	.00039	.00118	.00074	26.77	18,000
	12	10.0	.00079	.00197	.00085	33.86	20,000	.00039	.00118	.00061	24.41	20,000	.00028	.00079	.00053	18.9	18,000
	14	11.7	.00079	.00118	.00066	23.62	18,000	.00039	.00079	.00044	15.75	18,000	.00020	.00039	.00037	11.81	16,000
	16	13.3	.00039	.00079	.00043	13.78	16,000	.00020	.00039	.00031	9.84	16,000	.00012	.00028	.00018	5.12	14,000
0.7	2	1.4	.00472	.01181	.00164	98.43	30,000	.00394	.00984	.00144	86.61	30,000	.00315	.00591	.00142	70.87	25,000
	4	2.9	.00472	.00984	.00164	98.43	30,000	.00394	.00787	.00144	86.61	30,000	.00197	.00591	.00142	70.87	25,000
	6	4.3	.00472	.00787	.00164	98.43	30,000	.00315	.00591	.00146	78.74	27,000	.00197	.00394	.00116	51.18	22,000
	8	5.7	.00472	.00787	.00164	98.43	30,000	.00315	.00591	.00177	70.87	20,000	.00118	.00315	.00098	39.37	20,000
	12	8.6	.00276	.00472	.00138	55.12	20,000	.00157	.00315	.00120	43.31	18,000	.00059	.00197	.00077	27.56	18,000
0.75	16	11.4	.00079	.00197	.00081	27.56	17,000	.00039	.00118	.00069	23.62	17,000	.00031	.00079	.00055	17.72	16,000
	2	1.3	.00591	.01181	.00197	118.11	30,000	.00394	.01181	.00164	98.43	30,000	.00394	.00787	.00157	78.74	25,000
	3	2.0	.00591	.01181	.00197	118.11	30,000	.00394	.01181	.00164	98.43	30,000	.00394	.00787	.00157	78.74	25,000
	4	2.7	.00591	.01181	.00197	118.11	30,000	.00394	.01181	.00164	98.43	30,000	.00394	.00787	.00157	78.74	25,000
	5	3.3	.00591	.00984	.00197	118.11	30,000	.00394	.00984	.00151	90.55	30,000	.00394	.00591	.00142	70.87	25,000
	6	4.0	.00591	.00787	.00197	118.11	30,000	.00394	.00787	.00131	78.74	30,000	.00394	.00394	.00126	62.99	25,000
	8	5.3	.00394	.00787	.00197	98.43	25,000	.00197	.00787	.00126	62.99	25,000	.00197	.00394	.00118	47.24	20,000
	10	6.7	.00394	.00394	.00197	98.43	25,000	.00197	.00394	.00094	47.24	25,000	.00197	.00197	.00085	33.86	20,000
	12	8.0	.00197	.00394	.00177	70.87	20,000	.00118	.00394	.00091	36.22	20,000	.00079	.00197	.00085	30.71	18,000
	14	9.3	.00197	.00276	.00118	47.24	20,000	.00118	.00197	.00081	32.28	20,000	.00079	.00118	.00071	25.59	18,000
	16	10.7	.00118	.00197	.00079	28.35	18,000	.00079	.00118	.00071	25.59	18,000	.00039	.00079	.00071	22.83	16,000
	18	12.0	.00079	.00157	.00068	21.65	16,000	.00047	.00098	.00049	15.75	16,000	.00031	.00059	.00056	15.75	14,000
	20	13.3	.00039	.00118	.00055	17.72	16,000	.00039	.00079	.00044	14.17	16,000	.00028	.00039	.00042	11.81	14,000
	22	14.7	.00039	.00079	.00046	12.99	14,000	.00039	.00039	.00035	9.84	14,000	.00028	.00028	.00033	7.87	12,000
	25	16.7	.00031	.00039	.00030	7.09	12,000	.00020	.00020	.00023	5.51	12,000	.00016	.00016	.00022	4.33	10,000
	30	20.0	.00020	.00020	.00016	3.15	10,000	.00012	.00020	.00012	2.36	10,000	.00012	.00012	.00010	1.57	8,000
0.8	2	1.3	.00591	.01181	.00197	118.11	30,000	.00394	.00984	.00197	98.43	25,000	.00394	.00787	.00197	78.74	20,000
	4	2.5	.00591	.01181	.00197	118.11	30,000	.00394	.00787	.00181	90.55	25,000	.00315	.00591	.00177	70.87	20,000
	6	3.8	.00591	.00984	.00197	118.11	30,000	.00394	.00787	.00171	78.74	23,000	.00276	.00472	.00157	62.99	20,000
	8	5.0	.00394	.00787	.00197	98.43	25,000	.00276	.00591	.00197	78.74	20,000	.00197	.00394	.00175	62.99	18,000
	12	7.5	.00276	.00394	.00177	70.87	20,000	.00197	.00276	.00185	59.06	16,000	.00118	.00197	.00169	47.24	14,000
	16	10.0	.00118	.00197	.00089	28.35	16,000	.00079	.00118	.00084	23.62	14,000	.00059	.00079	.00079	18.9	12,000
	20	12.5	.00039	.00118	.00070	19.69	14,000	.00039	.00079	.00062	14.96	12,000	.00039	.00039	.00059	11.81	10,000
0.9	3	1.7	.00591	.01378	.00219	118.11	27,000	.00472	.01181	.00197	98.43	25,000	.00394	.00984	.00197	78.74	20,000
	4	2.2	.00591	.01378	.00219	118.11	27,000	.00472	.00984	.00197	98.43	25,000	.00394	.00787	.00177	70.87	20,000
	6	3.3	.00591	.01378	.00219	118.11	27,000	.00472	.00984	.00197	98.43	25,000	.00394	.00787	.00175	62.99	18,000
	8	4.4	.00394	.01181	.00197	98.43	25,000	.00315	.00787	.00197	90.55	23,000	.00315	.00591	.00162	55.12	17,000
	10	5.6	.00394	.01181	.00197	78.74	20,000	.00315	.00787	.00186	66.93	18,000	.00315	.00472	.00155	43.31	14,000
	12	6.7	.00276	.00787	.00157	62.99	20,000	.00197	.00591	.00151	51.18	17,000	.00197	.00472	.00136	35.43	13,000
	16	8.9	.00276	.00591	.00131	47.24	18,000	.00197	.00394	.00123	39.37	16,000	.00118	.00394	.00118	28.35	12,000
	18	10.0	.00197	.00394	.00131	39.37	15,000	.00118	.00315	.00113	31.5	14,000	.00079	.00315	.00107	23.62	11,000
	20	11.1	.00197	.00315	.00105	31.5	15,000	.00118	.00197	.00097	25.2	13,000	.00079	.00197	.00094	16.93	9,000
	22	12.2	.00118	.00197	.00085	25.59	15,000	.00079	.00118	.00085	20.47	12,000	.00059	.00118	.00084	13.39	8,000
	25	13.9	.00079	.00118	.00079	18.9	12,000	.00059	.00079	.00067	13.39	10,000	.00039	.00079	.00065	9.06	7,000
30	16.7	.00039	.00079	.00049	11.81	12,000	.00028	.00039	.00041	8.27	10,000	.00020	.00039	.00039	4.72	6,000	

## Recommended Conditions (Inch)

Work Material			Hardened Steels SKD61•STAVAX•HPM-38 (~52HRC)					Hardened Steels SKD11 (~62HRC)					High Speed Steels SKH (~65HRC)				
Corner Radius	Under Neck Length	L/D	Depth of Cut		Feed per tooth	Feed	Spindle Speed	Depth of Cut		Feed per tooth	Feed	Spindle Speed	Depth of Cut		Feed per tooth	Feed	Spindle Speed
			ap Inch	ae Inch	IPT fz	IPM	RPM	ap Inch	ae Inch	IPT fz	IPM	RPM	ap Inch	ae Inch	IPT fz	IPM	RPM
1	2	1.0	.00787	.01969	.00236	118.11	25,000	.00787	.01969	.00197	98.43	25,000	.00591	.01181	.00197	78.74	20,000
	3	1.5	.00787	.01969	.00236	118.11	25,000	.00787	.01969	.00197	98.43	25,000	.00591	.01181	.00197	78.74	20,000
	4	2.0	.00787	.01969	.00236	118.11	25,000	.00787	.01969	.00197	98.43	25,000	.00591	.01181	.00197	78.74	20,000
	6	3.0	.00787	.01575	.00197	98.43	25,000	.00787	.01181	.00157	78.74	25,000	.00591	.01181	.00157	62.99	20,000
	8	4.0	.00787	.01181	.00197	78.74	20,000	.00394	.00787	.00175	62.99	18,000	.00394	.00787	.00148	47.24	16,000
	10	5.0	.00394	.01181	.00219	78.74	18,000	.00394	.00787	.00197	62.99	16,000	.00394	.00394	.00169	47.24	14,000
	12	6.0	.00394	.00787	.00197	62.99	16,000	.00394	.00394	.00169	47.24	14,000	.00197	.00394	.00154	37.01	12,000
	13	6.5	.00315	.00787	.00197	62.99	16,000	.00236	.00394	.00169	47.24	14,000	.00157	.00315	.00154	37.01	12,000
	14	7.0	.00276	.00591	.00197	62.99	16,000	.00197	.00315	.00169	47.24	14,000	.00118	.00276	.00154	37.01	12,000
	16	8.0	.00276	.00591	.00197	62.99	16,000	.00197	.00315	.00169	47.24	14,000	.00118	.00276	.00154	37.01	12,000
1	18	9.0	.00197	.00394	.00197	55.12	14,000	.00118	.00197	.00164	39.37	12,000	.00079	.00118	.00167	33.46	10,000
	20	10.0	.00197	.00394	.00141	39.37	14,000	.00118	.00197	.00135	32.28	12,000	.00079	.00118	.00142	28.35	10,000
	22	11.0	.00118	.00315	.00120	33.46	14,000	.00079	.00236	.00115	27.56	12,000	.00079	.00079	.00118	23.62	10,000
	25	12.5	.00118	.00197	.00112	26.77	12,000	.00079	.00118	.00110	22.05	10,000	.00039	.00079	.00097	16.54	8,500
	27	13.5	.00079	.00197	.00082	19.69	12,000	.00059	.00118	.00081	16.14	10,000	.00039	.00079	.00076	12.99	8,500
	30	15.0	.00079	.00118	.00059	14.17	12,000	.00039	.00079	.00059	11.81	10,000	.00031	.00039	.00056	9.45	8,500
	32	16.0	.00079	.00079	.00045	9.06	10,000	.00039	.00059	.00044	7.09	8,000	.00031	.00039	.00043	5.91	6,800
	35	17.5	.00039	.00079	.00030	5.91	10,000	.00028	.00039	.00030	4.72	8,000	.00020	.00028	.00029	3.94	6,800
1.25	40	20.0	.00020	.00039	.00020	3.94	10,000	.00012	.00020	.00020	3.15	8,000	.00008	.00012	.00014	1.97	6,800
	4	1.6	.01181	.01969	.00295	118.11	20,000	.00787	.01969	.00246	98.43	20,000	.00591	.01575	.00219	78.74	18,000
	6	2.4	.01181	.01575	.00276	110.24	20,000	.00787	.01969	.00226	90.55	20,000	.00591	.01575	.00219	78.74	18,000
	8	3.2	.00984	.01181	.00256	102.36	20,000	.00591	.01181	.00207	82.68	20,000	.00472	.00984	.00197	70.87	18,000
	10	4.0	.00787	.01181	.00246	98.43	20,000	.00591	.00787	.00197	78.74	20,000	.00394	.00591	.00175	62.99	18,000
	15	6.0	.00394	.00787	.00219	78.74	18,000	.00276	.00591	.00197	62.99	16,000	.00197	.00394	.00169	47.24	14,000
	20	8.0	.00276	.00591	.00185	59.06	16,000	.00197	.00394	.00169	47.24	14,000	.00118	.00197	.00197	39.37	10,000
	25	10.0	.00197	.00394	.00141	39.37	14,000	.00118	.00276	.00139	33.46	12,000	.00079	.00118	.00177	28.35	8,000
1.5	30	12.0	.00118	.00276	.00118	28.35	12,000	.00079	.00197	.00126	25.2	10,000	.00039	.00079	.00163	22.83	7,000
	35	14.0	.00079	.00118	.00089	17.72	10,000	.00039	.00079	.00093	15.75	8,500	.00028	.00039	.00102	12.6	6,200
	6	2.0	.00787	.03150	.00295	118.11	20,000	.00787	.02362	.00273	98.43	18,000	.00787	.01969	.00281	78.74	14,000
	8	2.7	.00787	.03150	.00295	118.11	20,000	.00787	.02362	.00273	98.43	18,000	.00787	.01969	.00281	78.74	14,000
	10	3.3	.00787	.02362	.00246	98.43	20,000	.00787	.01575	.00219	78.74	18,000	.00394	.01181	.00211	59.06	14,000
	12	4.0	.00787	.02362	.00246	98.43	20,000	.00787	.01575	.00219	78.74	18,000	.00394	.01181	.00211	59.06	14,000
	14	4.7	.00394	.01575	.00219	78.74	18,000	.00394	.01181	.00197	62.99	16,000	.00394	.00787	.00197	47.24	12,000
	16	5.3	.00394	.01575	.00219	78.74	18,000	.00394	.01181	.00197	62.99	16,000	.00394	.00787	.00197	47.24	12,000
	18	6.0	.00394	.01181	.00197	70.87	18,000	.00394	.00787	.00172	55.12	16,000	.00394	.00591	.00180	43.31	12,000
	20	6.7	.00394	.01181	.00175	62.99	18,000	.00394	.00787	.00148	47.24	16,000	.00394	.00394	.00158	37.8	12,000
1.75	22	7.3	.00394	.00787	.00162	55.12	17,000	.00276	.00591	.00131	39.37	15,000	.00276	.00276	.00158	34.65	11,000
	25	8.3	.00394	.00787	.00148	47.24	16,000	.00276	.00591	.00129	36.22	14,000	.00197	.00276	.00158	31.5	10,000
	27	9.0	.00276	.00394	.00141	39.37	14,000	.00197	.00315	.00131	31.5	12,000	.00118	.00197	.00153	27.56	9,000
	30	10.0	.00276	.00394	.00105	29.53	14,000	.00197	.00276	.00105	25.2	12,000	.00118	.00197	.00137	23.62	8,600
	35	11.7	.00197	.00394	.00102	24.41	12,000	.00118	.00276	.00098	19.69	10,000	.00079	.00197	.00115	16.54	7,200
	40	13.3	.00118	.00276	.00089	17.72	10,000	.00079	.00197	.00077	12.6	8,200	.00039	.00118	.00080	10.24	6,400
	5	1.4	.01181	.03937	.00295	118.11	20,000	.00984	.03150	.00273	98.43	18,000	.00787	.02362	.00253	70.87	14,000
	10	2.9	.00984	.03937	.00295	118.11	20,000	.00787	.02362	.00273	98.43	18,000	.00591	.01969	.00239	66.93	14,000
	15	4.3	.00984	.03937	.00295	118.11	20,000	.00591	.01969	.00283	90.55	16,000	.00512	.01575	.00211	59.06	14,000
	20	5.7	.00709	.02362	.00273	98.43	18,000	.00394	.01181	.00236	70.87	15,000	.00394	.00787	.00197	47.24	12,000
1.75	25	7.1	.00472	.01378	.00221	70.87	16,000	.00394	.00787	.00225	62.99	14,000	.00236	.00472	.00197	39.37	10,000
	30	8.6	.00394	.00984	.00211	59.06	14,000	.00276	.00591	.00170	37.4	11,000	.00197	.00315	.00175	31.5	9,000
	35	10.0	.00315	.00787	.00182	47.24	13,000	.00276	.00472	.00158	31.5	10,000	.00118	.00236	.00171	25.59	7,500
	40	11.4	.00276	.00394	.00143	31.5	11,000	.00157	.00276	.00158	28.35	9,000	.00079	.00197	.00127	17.72	7,000
	45	12.9	.00236	.00276	.00138	27.56	10,000	.00138	.00197	.00157	23.62	7,500	.00059	.00118	.00105	12.6	6,000

## Recommended Conditions (Inch)

Work Material			Hardened Steels SKD61・STAVAX・HPM-38 (~52HRC)					Hardened Steels SKD11 (~62HRC)					High Speed Steels SKH (~65HRC)				
Corner Radius	Under Neck Length	L/D	Depth of Cut		Feed per tooth	Feed	Spindle Speed	Depth of Cut		Feed per tooth	Feed	Spindle Speed	Depth of Cut		Feed per tooth	Feed	Spindle Speed
			ap Inch	ae Inch	IPT fz	IPM	RPM	ap Inch	ae Inch	IPT fz	IPM	RPM	ap Inch	ae Inch	IPT fz	IPM	RPM
2	6	1.5	.01181	.05906	.00295	118.11	20,000	.00787	.03150	.00308	98.43	16,000	.00787	.02362	.00328	78.74	12,000
	8	2.0	.01181	.05906	.00295	118.11	20,000	.00787	.03150	.00308	98.43	16,000	.00787	.02362	.00328	78.74	12,000
	10	2.5	.01181	.05906	.00295	118.11	20,000	.00787	.03150	.00308	98.43	16,000	.00787	.02362	.00328	78.74	12,000
	12	3.0	.01181	.05906	.00295	118.11	20,000	.00787	.03150	.00308	98.43	16,000	.00787	.02362	.00328	78.74	12,000
	14	3.5	.01181	.05906	.00295	118.11	20,000	.00787	.03150	.00246	78.74	16,000	.00787	.02362	.00262	62.99	12,000
	15	3.8	.01181	.05906	.00295	118.11	20,000	.00787	.03150	.00246	78.74	16,000	.00787	.02362	.00262	62.99	12,000
	16	4.0	.01181	.03937	.00295	106.3	18,000	.00787	.02362	.00246	78.74	16,000	.00591	.01969	.00262	62.99	12,000
	18	4.5	.00787	.03937	.00295	106.3	18,000	.00591	.02362	.00253	70.87	14,000	.00472	.01575	.00276	55.12	10,000
	20	5.0	.00787	.03937	.00295	94.49	16,000	.00394	.02362	.00253	70.87	14,000	.00394	.01575	.00276	55.12	10,000
	22	5.5	.00787	.03150	.00246	78.74	16,000	.00394	.01969	.00211	59.06	14,000	.00394	.01181	.00236	47.24	10,000
	25	6.3	.00787	.03150	.00197	62.99	16,000	.00394	.01575	.00169	47.24	14,000	.00394	.00787	.00197	39.37	10,000
	27	6.8	.00591	.01969	.00197	62.99	16,000	.00394	.01181	.00169	47.24	14,000	.00276	.00787	.00197	39.37	10,000
	30	7.5	.00394	.01181	.00225	62.99	14,000	.00276	.00787	.00236	47.24	10,000	.00197	.00591	.00240	39.37	8,200
	35	8.8	.00394	.00787	.00169	47.24	14,000	.00276	.00591	.00197	39.37	10,000	.00197	.00394	.00197	32.28	8,200
	40	10.0	.00276	.00591	.00197	47.24	12,000	.00197	.00394	.00229	39.37	8,600	.00118	.00276	.00237	32.28	6,800
45	11.3	.00276	.00394	.00123	29.53	12,000	.00197	.00276	.00142	24.41	8,600	.00118	.00197	.00145	19.69	6,800	
50	12.5	.00197	.00315	.00108	21.65	10,000	.00118	.00197	.00131	19.69	7,500	.00079	.00118	.00150	16.54	5,500	
2.5	10	2.0	.01181	.05906	.00328	118.11	18,000	.00787	.04724	.00410	98.43	12,000	.00787	.02756	.00428	78.74	9,200
	15	3.0	.01181	.05906	.00328	118.11	18,000	.00787	.04724	.00410	98.43	12,000	.00787	.02756	.00428	78.74	9,200
	20	4.0	.01181	.04724	.00394	118.11	15,000	.00787	.03937	.00394	78.74	10,000	.00591	.01969	.00394	62.99	8,000
	25	5.0	.00787	.03937	.00328	98.43	15,000	.00591	.03150	.00412	70.87	8,600	.00394	.01181	.00328	47.24	7,200
	30	6.0	.00787	.03150	.00328	78.74	12,000	.00591	.01969	.00389	59.06	7,600	.00394	.00787	.00265	33.86	6,400
	35	7.0	.00591	.01969	.00295	59.06	10,000	.00394	.01181	.00297	43.31	7,300	.00276	.00591	.00246	29.53	6,000
	40	8.0	.00394	.00787	.00236	47.24	10,000	.00276	.00591	.00289	39.37	6,800	.00197	.00394	.00233	25.59	5,500
	45	9.0	.00394	.00591	.00197	39.37	10,000	.00276	.00394	.00234	29.92	6,400	.00197	.00276	.00226	21.65	4,800
50	10.0	.00315	.00394	.00175	31.5	9,000	.00197	.00276	.00174	20.87	6,000	.00118	.00197	.00177	14.17	4,000	
3	8	1.3	.01181	.07874	.00369	118.11	16,000	.01181	.04724	.00615	98.43	8,000	.00787	.03937	.00562	78.74	7,000
	10	1.7	.01181	.07874	.00369	118.11	16,000	.01181	.04724	.00615	98.43	8,000	.00787	.03937	.00562	78.74	7,000
	12	2.0	.01181	.07874	.00369	118.11	16,000	.01181	.04724	.00615	98.43	8,000	.00787	.03937	.00562	78.74	7,000
	15	2.5	.01181	.07874	.00369	118.11	16,000	.01181	.04724	.00615	98.43	8,000	.00787	.03937	.00562	78.74	7,000
	18	3.0	.01181	.07874	.00369	118.11	16,000	.01181	.04724	.00615	98.43	8,000	.00787	.03937	.00562	78.74	7,000
	20	3.3	.01181	.07874	.00369	118.11	16,000	.01181	.04724	.00615	98.43	8,000	.00787	.03937	.00562	78.74	7,000
	25	4.2	.01181	.05906	.00369	118.11	16,000	.00787	.03937	.00492	78.74	8,000	.00591	.02756	.00422	59.06	7,000
	30	5.0	.00787	.05906	.00422	118.11	14,000	.00787	.03937	.00547	78.74	7,200	.00591	.02756	.00454	59.06	6,500
	35	5.8	.00787	.04724	.00363	94.49	13,000	.00669	.03150	.00463	62.99	6,800	.00472	.01969	.00407	47.24	5,800
	40	6.7	.00787	.03937	.00295	70.87	12,000	.00591	.02362	.00369	47.24	6,400	.00394	.01575	.00379	39.37	5,200
	50	8.3	.00394	.02362	.00288	47.24	8,200	.00394	.01181	.00353	33.86	4,800	.00197	.00787	.00305	24.41	4,000
60	10.0	.00276	.01181	.00197	23.62	6,000	.00197	.00591	.00277	17.72	3,200	.00118	.00276	.00236	11.81	2,500	
Notes			<p>※ Recommended RPM based upon ideal conditions.                      RPM may be adjusted to match the capabilities of your machine while maintaining constant feed rate per cutting tooth.                      ※1 Depth of Cut : ap = Axial Depth of Cut / ae = Radial Depth of Cut.                      ※2 We recommend using oil mist coolant.                      ※3 Adjust both spindle speed and feed at the same rate.                      ※4 Adjust milling conditions according to the volume of depth of cut and rigidity of machine.                      ※5 Length of tool overhang must be as short as possible.</p>														

# Features of NS TOOL

## Being particular manufacturing that continues to maintain stable accuracy and quality

What is important in NS TOOL's product manufacturing is not only the high quality, but also the absolute quality of always maintaining the high quality and continuing to deliver the same high-precision products.



In- house development tool grinder TGM

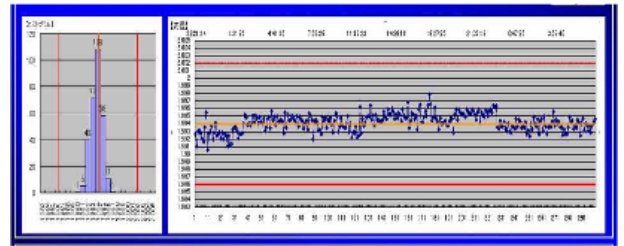

Realize stable production accuracy

### ■ Strengths for small diameter sizes under $\phi$ 6mm

#### The accuracy and quality of NS TOOL's end mills support micro and precision machining

NS TOOL, which delivers small-diameter end mills to customers, is responsible for product stability. The in-house developed tool grinding machine TGM, which was developed to realize that desire, has made it possible to suppress product variations and deliver products with stable accuracy and quality to customers every time.



#### Dia. tolerance

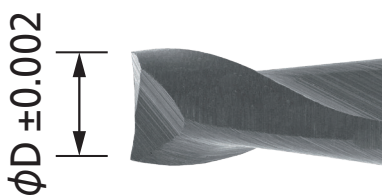

NSME230  $\phi$ 0.03 mm

#### R tolerance

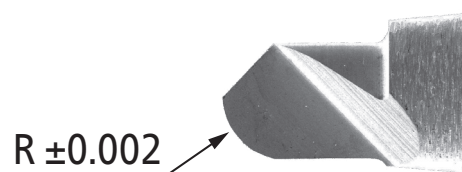

NSMB100 R0.005 mm

## ■ Uncompromising on shank accuracy as the basis of the tools

The end mill shank is the part that is attached to the machine tool both when using the end mill and when manufacturing the end mill. The shank is the standard for end mills and is a very important part of the basis of high precision. NS TOOL is particular about the accuracy of the shank, which is the standard, and manufactures it in the 2  $\mu\text{m}$  range of "-0.001 mm to -0.003 mm". (Excludes some products.)

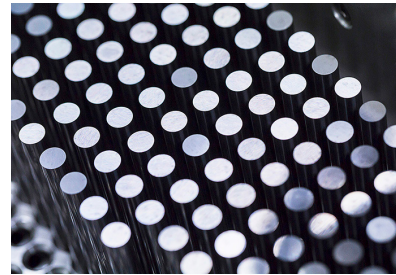
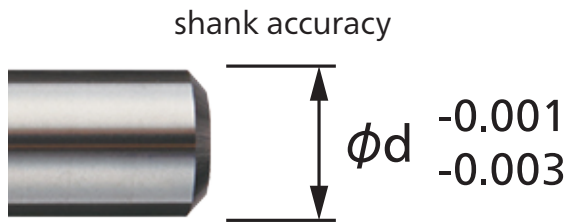

## ■ Inspections in each process

### Support micro precision machining with NS TOOL accuracy and quality

NS TOOL inspects end mills in each process to ensure high quality, and find out any occurred abnormalities at early process by inspective system



## ■ Responsibility for stable supply

End mills have become indispensable for cutting, and we are working on various earthquake countermeasures so that supply will not be interrupted. In addition to the measures for buildings mentioned above, we also take thorough measures to prevent falls, prevent glass from scattering, and protect measuring instruments and production equipment. As one of them, we also develop our own seismic detector device. We aim to be the most disaster-resistant factory in the world without stopping the production of our customers.





## NS TOOL CO.,LTD.

www.ns-tool.com  
6F., Sumitomo Fudosan Oimachi Ekimae Bldg.,  
1-28-1 Oi, Shinagawa-ku, Tokyo 140-0014, Japan  
TEL. +81-3-3774-2459 FAX. +81-3-3774-2460

## NS TOOL USA, INC.

us.ns-tool.com  
2265 Building # 3, Star CT.,  
Rochester Hills, MI 48309, USA  
TEL. +1-248-829-1960



### CAUTION

### Attention on Safety

- 1) When removing tools from cases, be careful of getting-out of tools and don't touch directly the cutting edges.
- 2) Never touch the cutting edges directly with bare hand.
- 3) Use safety covers and eye protection, as tools may be broken.
- 4) Use holders, etc. that match the tools and nature of the processing operations. The tool should be firmly attached to the holder to prevent shaking.
- 5) The work materials clamp firmly.
- 6) Make sure of dimensions of tools and work pieces before starting operation.
- 7) It is necessary to adjust conditions according to the dimensions of work materials and the machine.
- 8) Select a cutting fluid appropriate to the particular usage. Using a non-water cutting fluid could lead to fires due to sparks generated during processing or heat caused by breakage. Ensure that you take proper fire-prevention measures.
- 9) If abnormal sound, etc. occurs during processing, stop the machine immediately.
- 10) Don't modify tools.

